

Downtown Brockton Smart Growth District Design Standards

Table of Contents

1. Introduction
2. Purpose
3. Applicability
4. Definition of Terms
5. Application Procedures
6. Guiding Principles
 - 6.1. Coordination with Infrastructure
 - 6.2. Protect and Preserve the Historic and Cultural Heritage of Brockton
 - 6.3. Promote Flexibility and Variety in Future Development
 - 6.4. Promote Mix of Uses
 - 6.5. Sustainability
 - 6.6. Guiding Principles for Sub-Districts
 - 6.6.1. Arts / Culture
 - 6.6.2. Corcoran
 - 6.6.3. Downtown Core
 - 6.6.4. Ralsco
 - 6.6.5. Star Market
7. Standards for Compliance: Scale, Proportion, and Exterior Appearance of Buildings
8. Building Forms
 - 8.1. Building Forms
 - 8.2. Single-Family Detached (35')
 - 8.3. Two-Family (35')
 - 8.4. Three-Family (35')
 - 8.5. Three-Family (45')
 - 8.6. Multi-Family (45')
 - 8.7. Multi-Family (>45')
 - 8.8. Mixed-Use (45')
 - 8.9. Mixed-Use (>45')
 - 8.10. Renovation
9. Additional Standards for Compliance
 - 9.1. Placement, Alignment, Width, and Grade of Streets and Sidewalks
 - 9.2. Exterior Signs
 - 9.3. Lighting
 - 9.4. Stormwater Management
 - 9.5. Off-Street Parking
 - 9.6. Landscaping

Introduction, Purpose and Applicability

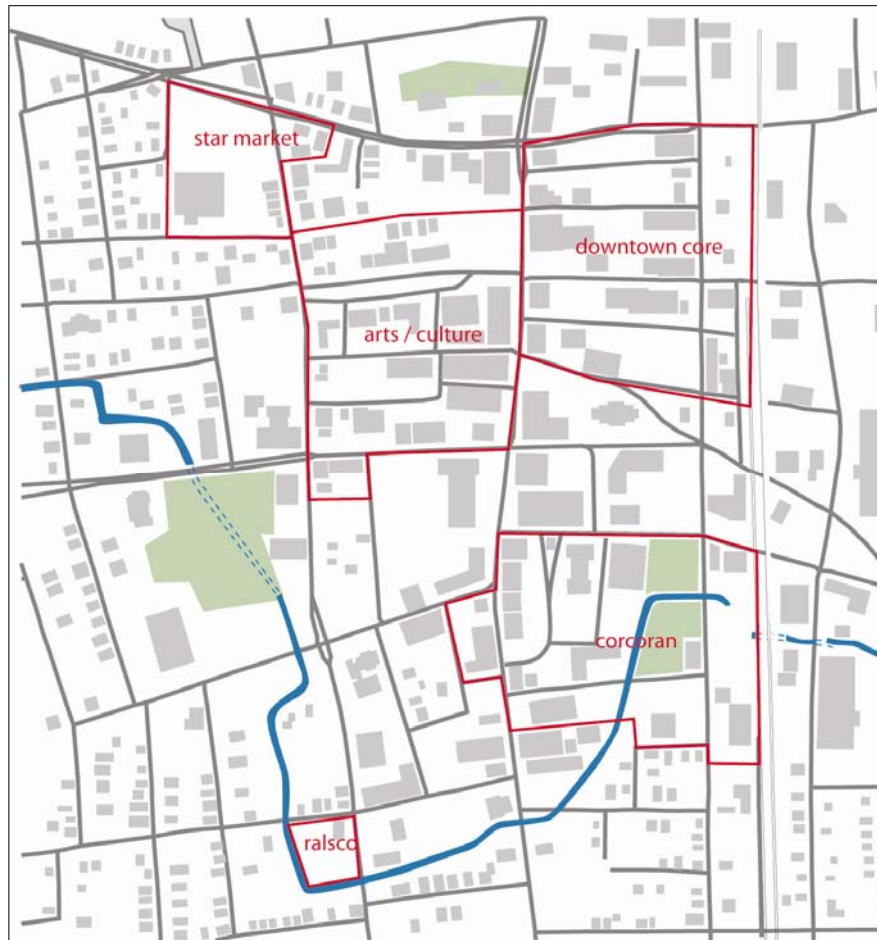

1. Introduction

These Design Standards are adopted pursuant to the authority of Mass. Gen. Laws Ch. 40R “Smart Growth Zoning” and 760 CMR 59.00, and Section 27-7 of the Zoning Ordinance (the “District Ordinance”) of the City of Brockton. They complement the District Ordinance, and provide the City of Brockton with a regulatory framework that will define the site design requirements for development within the Downtown Brockton Smart Growth District.

This document is organized into subject headings based on the areas of regulation. Several sections include both non-binding Guiding Principles and binding Standards for Compliance. The Guiding Principles identify the City’s goals and aspirations for the District and provide focus to the project’s planning and design. The Standards for Compliance include specific design requirements. Where it provides greater clarity regarding desired design outcomes, illustrative images have been used to complement these Design Standards. In some instances, where noted, images have been used to illustrate design features that are not permitted within the District. Captions have been added to images as necessary to clarify the intent of the illustration and to reinforce the Standards for Compliance included in the text.

2. Purpose

The Design Standards supplement the District Ordinance, and include both binding Standards for Compliance and non-binding Guiding Principles that apply distinctly to each of the five Sub-districts in the District. The Standards for Compliance shall be used by the Planning Board of the City of Brockton (the “Planning Board”) in their review and consideration of Development Projects proposed pursuant to the District Ordinance.

Introduction, Purpose and Applicability

These Design Standards shall be in effect upon adoption by a majority of the Planning Board and approval of the Department of Housing and Community Development (“Department”). The Design Standards as authorized by Mass. Gen. Laws Ch. 40R may be amended from time to time with the approval of the Department.

A Development Project shall be approved by the Planning Board upon a finding that it complies with the District Ordinance and the Standards for Compliance included in these Design Standards. In the case of inconsistency between the District Ordinance and these Design Standards, the District Ordinance shall govern. In the case of inconsistency between applicable state or federal laws, including, without limitation, state building codes or life safety codes, and these Design Standards, the applicable state and federal laws, rules and regulations shall govern. These Design Standards do not exempt Applicants from obtaining all applicable permits necessary for development within the District including, without limitation, state building codes or life safety codes.

3. Applicability

The Standards for Compliance contained herein shall apply to Development Projects within the District that are subject to Site Plan Approval under the District Ordinance. The Applicant shall comply with the Standards for Compliance contained herein, unless an exemption from the Standards for Compliance is specifically authorized by the Planning Board. Such exemption may be concurrent with the review process.

4. Definition of Terms

Definitions of technical or other capitalized terms used in this document can be found in Section 27-27.7 of the City of Brockton Zoning Ordinance, as supplemented by additional definitions as follows:

ALLEY -- A type of traveled way found in densely populated areas. Alleys usually run between or behind buildings to allow for delivery and collection. Alleys may provide access to private garages for the use of adjacent dwelling units, and may provide parking or access for fire engines.

BUILDING FORMS – Graphical depictions of dimensional requirements such as height, setbacks and façade differentiation applicable to specific building types.

DESIGN STANDARDS – Regulations adopted pursuant to Section 27-27.7(I) of the District Ordinance and approved by the Massachusetts Department of Housing & Community Development pursuant to M.G.L. c.40R, § 10 and applicable regulations. Design Standards are applicable to all Development Projects within the District that are subject to Site Plan Review by the Approving Authority under the District Ordinance.

DEVELOPMENT PROJECT – A residential or mixed-use development undertaken pursuant to the District Ordinance.

DISTRICT – The Downtown Brockton Smart Growth Overlay District defined in Section 27-27.7 of the City of Brockton Zoning Ordinance.

DISTRICT ORDINANCE – Section 27-27.7 of the City of Brockton Zoning Ordinance.

GUIDING PRINCIPLES -- A set of design and site planning principles intended to provide guidance to the Applicant in the development of a project within the District. Guiding Principles are non-binding.

IESNA -- Illuminating Engineering Society of North America (IES or IESNA), the professional society of lighting engineers, including those from manufacturing companies, and others professionally involved in lighting.

LUMINAIRE – A complete lighting system, including a lamp or lamps and a fixture.

OPEN SPACE -- An area of land such as a square, green, neighborhood park, pocket park, and linear pedestrian park which is located and designed for public access by pedestrians and/or bicyclists for passive or active recreation.

PEDESTRIAN WAY – A way intended for use by the general public for the movement of pedestrians which may include provision for use by cyclists. The District may include but is not limited to the following types of Pedestrian Ways:

SIDEWALK -- A Pedestrian Way that is located immediately adjacent to and incorporated within the design of a street. A Sidewalk may, but need not, immediately abut a Development Project.

4. Definition of Terms

PATH -- A Pedestrian Way that is not located immediately adjacent to and incorporated within the design of a street. A Path may meander where appropriate to site design rather than the strictly orthogonal configuration expected of a Sidewalk. A Path may provide a pedestrian connection between points of interest in the District, provide access to and among parking areas, or other uses.

PASS-THROUGH WALKWAYS – A Pedestrian Way designed solely for pedestrian use and intended to provide mid-block pedestrian access between Streets or access from parking areas to the Street which may be adjacent to storefronts, architectural or landscape elements.

RESIDENTIAL OPEN SPACES – Public and/or private open spaces or yards accessible to residents.

SERVICE AND LOADING AREA – Exterior locations of a building including but not limited to loading, delivery and service bays, dumpsters or containerized trash receptacles, metering stations, and utilities.

SETBACK -- The minimum horizontal distance between the lot line, property line or edge of a right-of-way and the nearest front, side, or rear line of the building (as the case may be), including terraces or any covered projection thereof, excluding balconies, stoops or steps.

STANDARDS FOR COMPLIANCE – A set of binding design and site planning requirements that are applicable to all Development Projects within the District that are subject to Site Plan Review pursuant to the District Ordinance.

STREET -- The right-of-way, including sidewalks, of a public way, or private way used or intended for use by vehicular traffic.

SUB-DISTRICTS -- A specific and defined area of land within the Downtown Brockton Smart Growth Overlay District that is subject to specific requirements for allowable uses or dimensional requirements that may differ from the requirements for allowable uses or dimensional requirements in other specific and defined areas within the Downtown Brockton Smart Growth Overlay District.

ZERO LOT LINE – The location of a building on a lot in such a manner that one or more of the building's sides rests directly on a lot line.

5. Application Procedures

- 5.I. Application procedures. Applicants for development within the District shall comply with the application requirements set forth in the District Ordinance.
- 5.I.1. Application contents. All Applications for Site Plan Approval pursuant to the District Ordinance shall be comprised of the following:
- 5.I.1.a. Completed application form.
 - 5.I.1.b. Complete list of abutters signed by Assessor, including address labels.
 - 5.I.1.c. Proposed Site Plan drawings stamped by a Massachusetts Registered Professional Engineer or other appropriate professional including one (1) original and nine (9) copies at 24" x 36" dimension; and two (2) paper copies at 11" x 17". The Site Plan drawings shall contain the following information:
 - 5.I.1.c.(i) Project name, boundaries, north arrow, date scale.
 - 5.I.1.c.(ii) Names and address of Applicant and project engineer.
 - 5.I.1.c.(iii) Names of abutting property owners
 - 5.I.1.c.(iv) Proposed names of new street(s), if any.
 - 5.I.1.c.(v) Stormwater management plan, including calculations of pre- and post-development rates and volumes, and including Operations & Maintenance Plan.
 - 5.I.1.c.(vi) Data to determine location, direction, width and length of every Traveled Way line, lot line, easement, zoning district and boundary line.
 - 5.I.1.c.(vii) Indication of purpose for easements.
 - 5.I.1.c.(viii) Existing and proposed topography at one-foot contours.
 - 5.I.1.c.(ix) A statement detailing proposed public improvements as may be necessary to mitigate extraordinary adverse impacts of the Development Project.
 - 5.I.1.d. Building elevation drawings.
 - 5.I.1.e. Study model shall be submitted when designing major construction projects occupying more than ___ sf of land to demonstrate the relationships and scale of the building to the existing built environment.
- 5.I.2. All waiver requests from provisions of the District Ordinance or these Design Standards shall be made in writing, and shall cite the specific provision(s) for which a waiver is requested.

5. Application Procedures

Schematic Illustration of Timeline for Site Plan Approval Process pursuant to the District Ordinance

*This is intended for illustrative purposes only.
The Applicant is responsible for complying with all Administrative requirements of the District Ordinance and these Design Standards.*

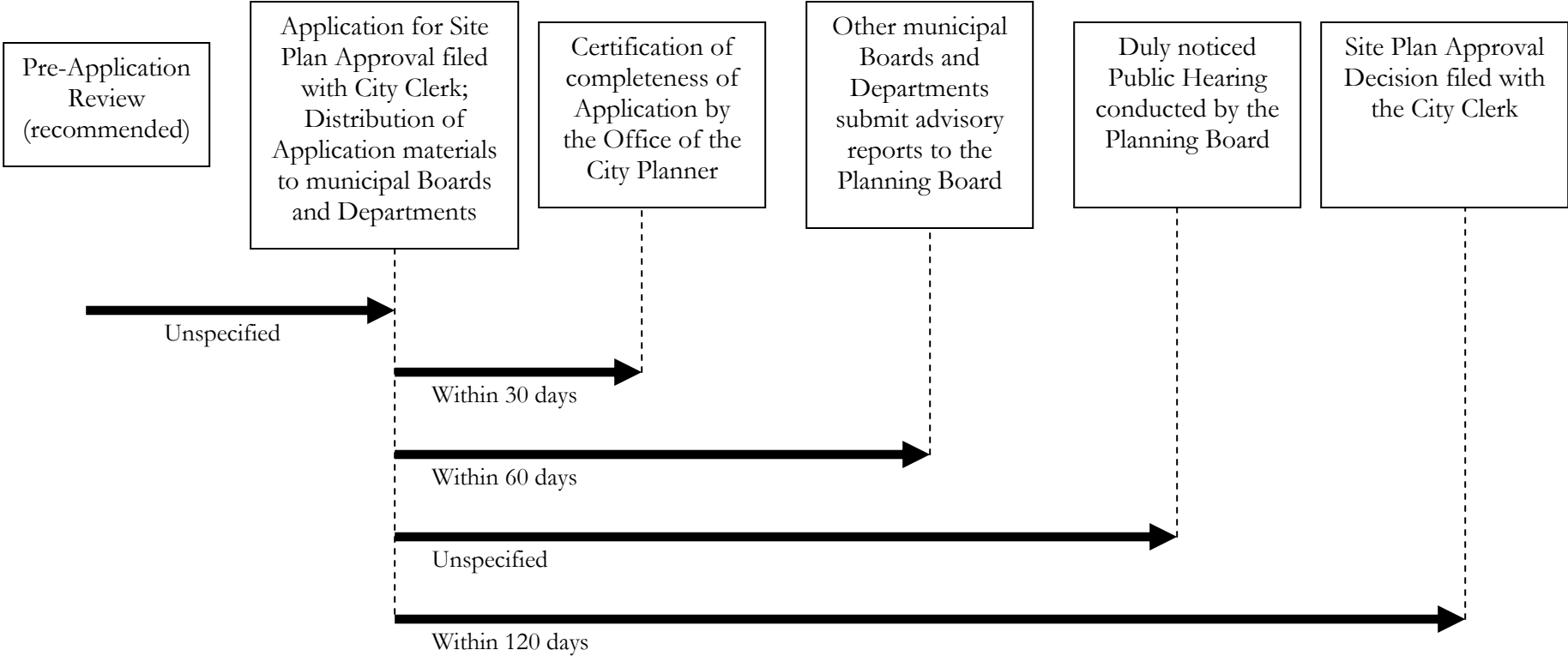

6. Guiding Principles

These Design Standards are based on site planning and design principles that articulate public interests in the physical design and aesthetic qualities associated with the land and its development. The following recommended provisions should be considered by the Applicant in designing the overall composition of the site, building improvements and related infrastructure improvements. These Guiding Principles are goals, and shall not be applied as regulatory standards.

6.1. Protect and Preserve the Historic & Cultural Heritage of Downtown Brockton

The Sanborn maps shown here illustrate Brockton's historical development patterns circa the first half of the 20th Century. New development should emphasize the conservation of buildings or groups of buildings that have architectural or historic significance, or are listed within public plans or policy documents as contributing to the character of Brockton. Adaptive reuse and renovation of existing buildings is encouraged where feasible. New construction should be complementary to the existing architectural design and building forms in Downtown Brockton.

6.2. Promote Flexibility and Variety in Future Development

These guidelines can not account for every proposal that will come before the Approving Authority and therefore strive to allow for creativity and variety, provided the end result is of high quality and an asset to the City. Variety and coherence are not mutually exclusive. Replicating one or two particular styles throughout Downtown Brockton will create an uninteresting streetscape, so creativity with design integrity is encouraged.



6. Guiding Principles



6.3. Promote Mix of Uses

Downtown Brockton is a central element of the City of Brockton's tax base. Manufacturing and industrial production is not likely to return to Downtown Brockton, but this location will remain significant to the cultural, economic and residential character of the City of Brockton in the future. The District may become a destination for employers, as well as educational, cultural or recreational institutions serving a local or regional population base, and the overall site design within the District should allow for such non-residential development and investment as may be economically viable and culturally beneficial.

6.4. Sustainability

Sustainable construction techniques and materials should be incorporated in new construction in the District. Renovation of existing buildings should seek to improve energy efficiency both within the building and in terms of the development's relationship to the city. Energy efficiency should be a central goal in selection of lighting, windows, materials, insulation and heating / ventilation / air conditioning systems. Wayfinding signage should be installed to encourage walking and the use of public transit. Mixed-uses within the District and allowance for higher development densities is intended to result in structures that will become more efficient and less consumptive of energy resources relative to lower density development patterns. Increased use of alternative transportation methods is expected to result in a reduction in typical vehicle miles traveled per unit of development.

6.5. Coordination with Infrastructure

New development fronting on public streets should propose improvements to the public infrastructure including traffic improvements, sidewalks and crosswalks, street lighting, burial of existing overhead utility lines, street trees and/or other landscaping enhancements. Where new development is proposed in proximity to existing public parks or open spaces, the Applicant should consider proposing enhancements to these public spaces and the pedestrian connections between said spaces and the new development.

6. Guiding Principles

6.6.1. *Arts / Culture*

The Arts / Culture Sub-district includes a diverse mix of building uses and scales, and includes some of the most attractive and distinctive architecture in Downtown Brockton. Legion Parkway is the primary east-west corridor in the Sub-district, and with a double-barrel boulevard layout is among the most distinctive pedestrian corridors in Downtown Brockton. This corridor includes existing retail and mixed-use development fronting on wide sidewalks with many curbside parking spaces. It is an excellent location for additional development of both housing and convenience retail outlets. The new Brockton Neighborhood Health Center, at the corner of Legion Parkway and Main Street, will become both a visual focal point and a center of activity in Downtown Brockton. Frederick Douglass Avenue, running parallel to Legion Parkway to the south, is home to the Brockton African American History Museum, and has been identified as a potential location for new uses such as a restaurant or jazz cafe. Cultural uses such as performance or visual arts exhibition space would enhance and strengthen the existing mix of retail / commercial, residential and cultural / institutional uses. The Arts / Culture Sub-district will benefit from reinvestment in both smaller scale residential development, and in mixed-use development with first floor retail / commercial and upper story residential uses.

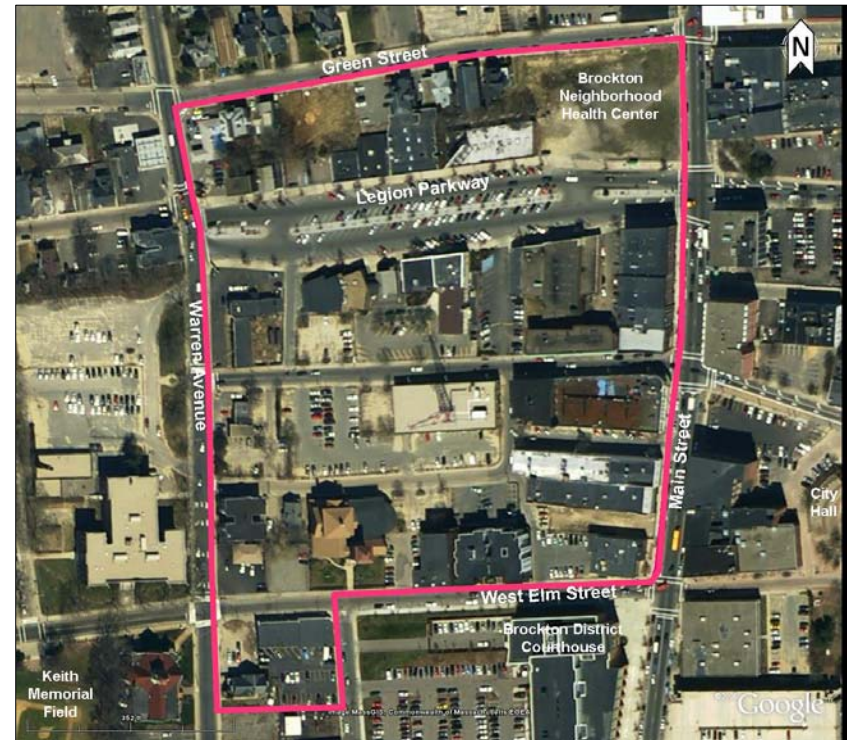

Arts/Culture Sub-District



6. Guiding Principles

6.6.2. *Corcoran*

The Corcoran Sub-district is characterized by a mix of commercial and residential uses, complemented by attractive public parks and an expanded public library as well as a significant length of frontage on the Salisbury River. The Sub-district includes several significant publicly-owned properties, both in active and unproductive uses. Underutilized publicly-owned sites represent significant opportunities for redevelopment through City issuance of competitive Requests for Proposal. The Corcoran building, currently in use as a storage facility for public records, is located on Montello Street, and presents the first impression of Downtown Brockton for visitors approaching the area from the south. This property could be revitalized through a mix of historic renovation of the primary structure into loft-style residential units, with potential for new construction of townhomes or multi-family housing on the adjacent undeveloped land. Significant potential for residential redevelopment exists in this sub-district thanks to both its transit-accessible location, the natural amenity provided by the Salisbury River, and the substantial investment in public infrastructure and parks that has taken place in recent years.

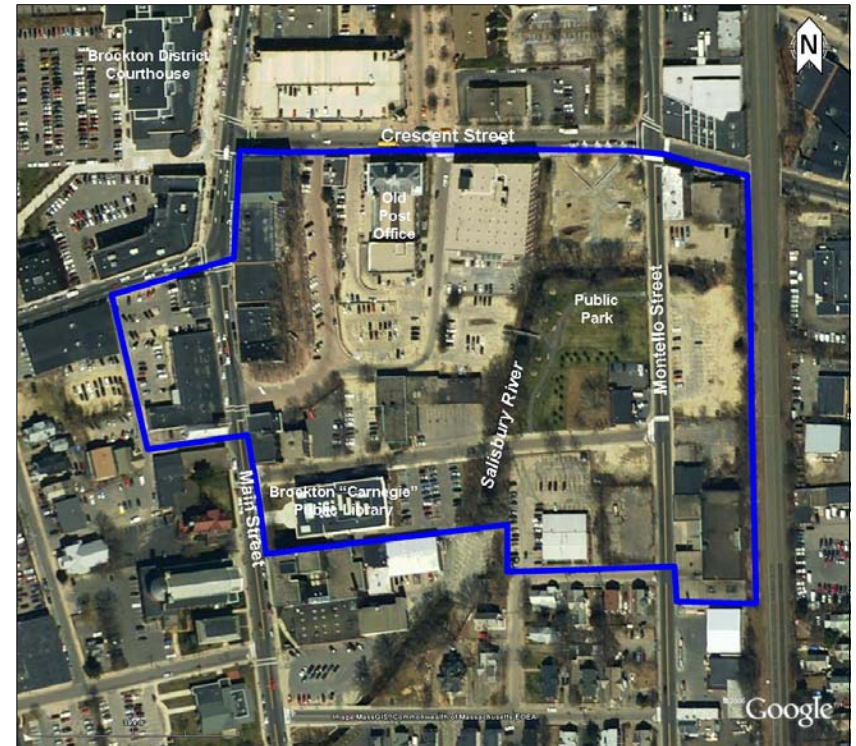

Corcoran Sub-District

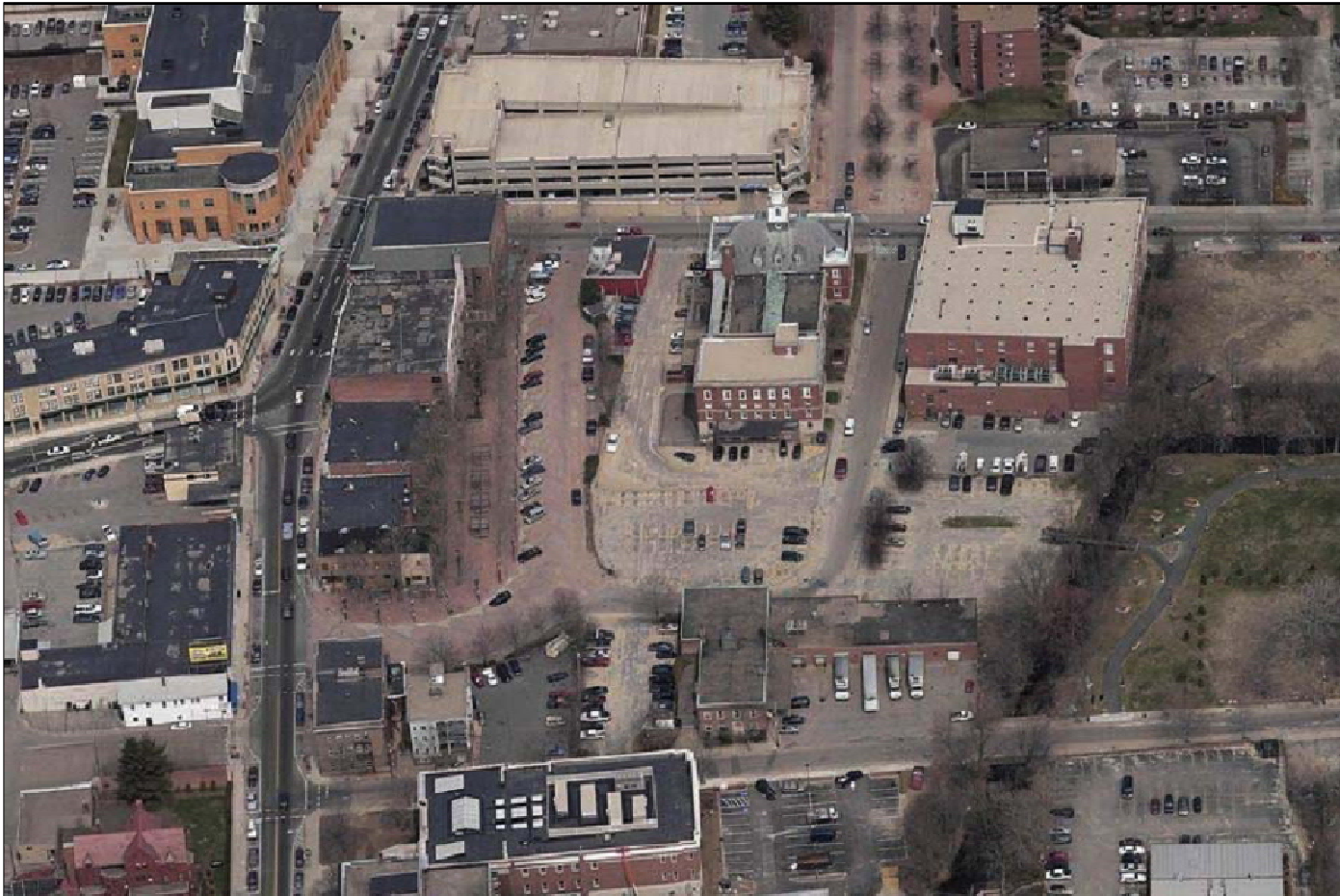

6. Guiding Principles

6.6.3. *Downtown Core*

The Downtown Core Sub-district includes a combination of larger scale commercial, office and industrial / warehousing uses, as well as several large surface parking lots. Landscaping and public amenities in this Sub-district are limited, and substantial investments in the public infrastructure including lighting, streetscape, and parking will help to make this a successful location for residential development. The smart growth zoning includes greater allowable building scales and densities in the Downtown Core than the other Sub-districts in order to both match the scale of existing larger buildings, and to stimulate substantial private investment in Downtown Brockton. City leaders are pursuing financing for a new public parking garage that could provide parking capacity for substantial new private development on parcels within walking distance. This Sub-district also includes several significant publicly owned parcels, many of which are currently in use as surface parking lots. A new parking structure would facilitate the redevelopment of parcels in both private and public ownership, and new private investment in this Sub-district, including redevelopment of underutilized public parcels, may provide a supplemental financing source for public construction of a parking garage.



Downtown Core Sub-District

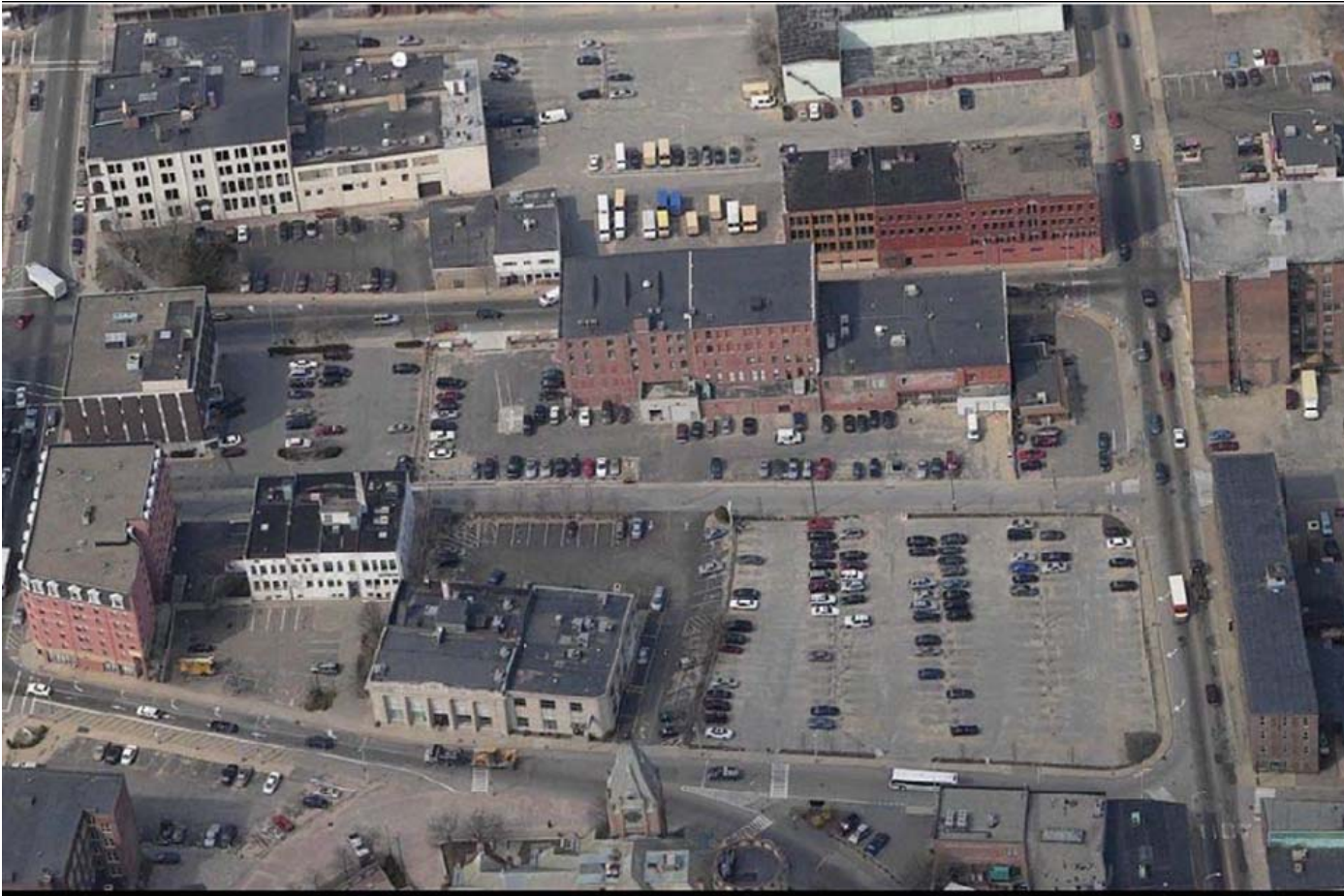

6. Guiding Principles

6.6.4. *Ralsco*

The Ralsco Sub-district includes a city-owned vacant lot bordered on the south and west sides by the Salisbury River, making it one of the longest stretches of riverfront in Downtown Brockton. This natural amenity enhances the opportunity to redevelop the site with residential development that enhances public access to the river for the benefit of both neighborhood residents and the general public. The City anticipates issuing a competitive Request for Proposals for residential redevelopment of the site including a requirement for establishment of a permanent access easement to extend the network of sidewalks and paths comprising the Salisbury Riverwalk. The Ralsco site is adjacent to a commercial use at the corner of Warren Avenue and Bartlett Street, and surrounded on all sides by primarily residential uses. The residential uses are typically 2- to 3-story single-family and 2- to 3-family homes. The smart growth zoning allows this pattern of development to extend onto the vacant Ralsco site, including single-family and 2- to 3-family residential uses at building scales that will complement neighboring properties. Residential development should also strive to reinforce the existing streetlines, with setbacks from public ways matching existing and historical setbacks.



Ralsco Sub-District

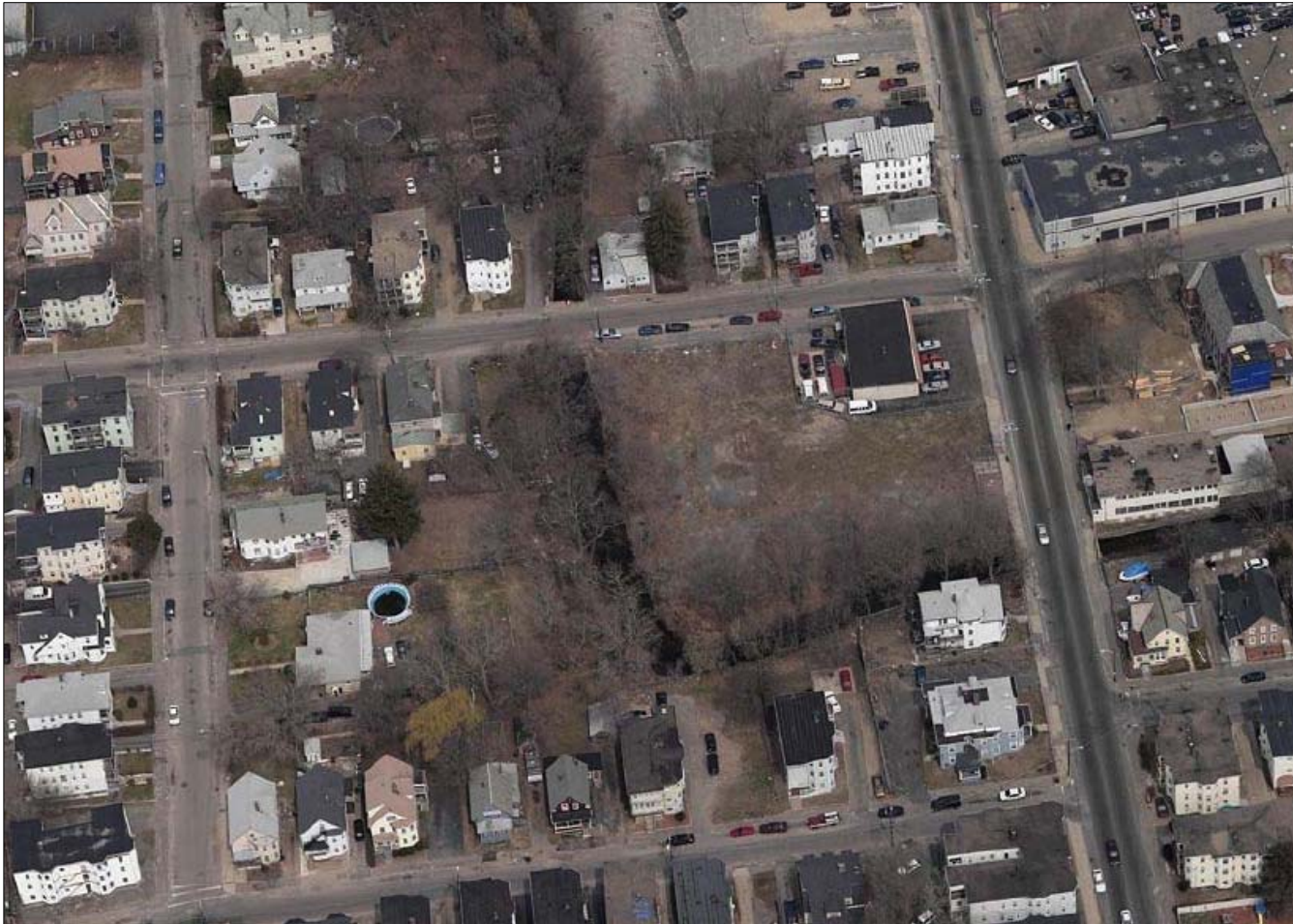

6. Guiding Principles

6.6.5. *Star Market*

The Star Market Sub-district includes a long-vacant retail use surrounded by a large field of parking with poor lighting and very little landscaping. The surrounding neighborhoods include both residential uses and a mix of smaller retail uses, with both stable retail uses and other vacant retail sites. The residential uses are typically 2- to 3-story single-family and 2- to 3- family homes. The smart growth zoning allows this pattern of development to extend onto the vacant Star Market site, including single-family and 2- to 3-family residential uses at building scales that will complement and enhance neighboring properties. The zoning also allows for 3-story mixed-use development with first floor retail. Mixed-use development should be located on Pleasant Street or at the intersection of Pleasant Street and Warren Avenue, and should front directly on one or both of those streets with parking located at the side and rear of the building(s). Residential development should strive to reinforce the existing streetlines, with setbacks from public ways matching existing and historical setbacks.

Many people drive past this location on Pleasant Street on their way into Downtown Brockton. It is therefore important that redevelopment of this "gateway" location exemplify the style and quality of architecture and site design that will characterize the revitalization of Downtown Brockton. A visually distinct and exciting building, including an architectural focal point that is taller than the building itself, such as a tower, turret or cupola is encouraged at the intersection of Pleasant Street and Warren Avenue.



Star Market Sub-District

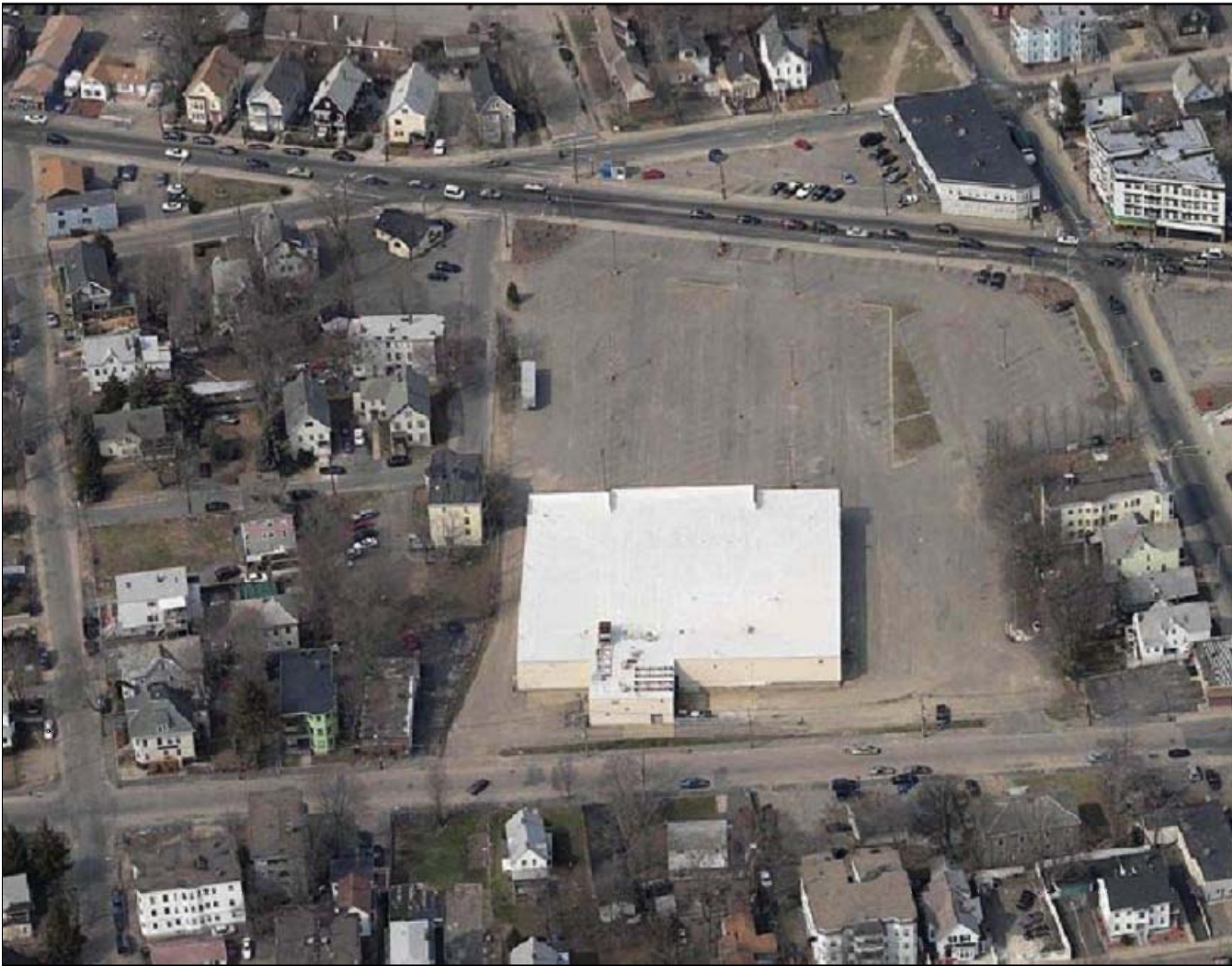

7. Scale, Proportions and Exterior Appearance of Buildings

7.1. *General*

- 7.1.1. Proposed developments should reflect the terrain and the use, scale, and architecture of existing buildings in the vicinity that have a functional or visual relationship to the proposed buildings. The development should acknowledge and respect the surrounding existing patterns of development, and should be such that those desirable existing patterns are complemented and strengthened.
- 7.1.2. New construction should respect traditional, significant, or historic uses or structures. When appropriate, the Planning Board will consult with and request opinions and information from the Brockton Historical Commission regarding specific structures or groups of structures.
- 7.1.3. Protection of public safety. Site design shall include adequate water supply distribution and storage for fire protection. Vehicular circulation shall meet the access needs of emergency and public safety vehicles. The adequacy of the foregoing public safety measures shall be based on the reasonable requirements of the Brockton Chief of Police and Fire Chief, in their respective fields.

7.2. *Materials, texture, and color*

- 7.2.1. New materials should reflect the character of Downtown Brockton and should be selected to convey a sense of quality, durability and permanence. Buildings shall use materials that are durable, economically maintained, and of a quality that will retain their appearance over time.



7. Scale, Proportions and Exterior Appearance of Buildings

- 7.2.2. Building façade materials permitted within the district include but are not limited to, brick, wood, cementitious fiber board, manufactured limestone, cast stone, masonry, stone, glass, terra cotta, cellular PVC trim, tile and sustainable materials.
- 7.2.3. Full size brick veneer is preferable to brick tile. Brick veneers should be mortared to give the appearance of structural brick. If used, brick tile applications should use wraparound corner and bullnose pieces to minimize a veneer appearance.
- 7.2.4. Stone and stone veneers are appropriate as a basic building material or as a special material for wall panels or sills in combination with other materials such as brick and concrete.
- 7.2.5. Poured-in-place concrete and pre-cast concrete are appropriate as a basic building material with special consideration to formwork, pigments, and aggregates that can create rich surfaces. Stone or tile accents are recommended.
- 7.2.6. Prohibited materials. Vinyl siding is prohibited. The use of exterior insulation finishing system (EIFS) is prohibited.
- 7.2.7. A combination of materials should be used in order to create visual interest.
- 7.2.8. Where more than one material is used, traditionally heavier materials (stone, brick, concrete with stucco, etc.) should be located below lighter materials (wood, fiber cement board, siding, etc). The change in material should occur along a horizontal line, preferably at the floor level.

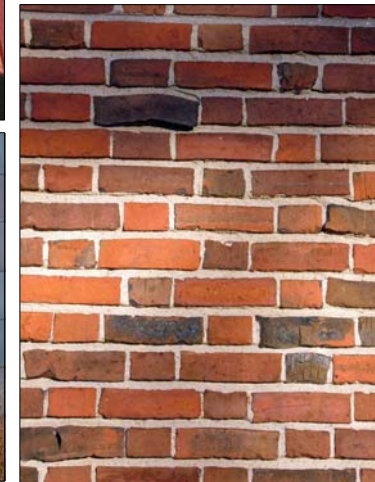
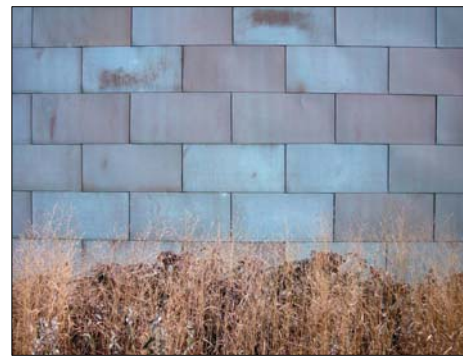
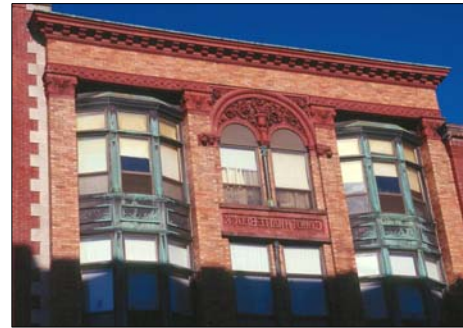
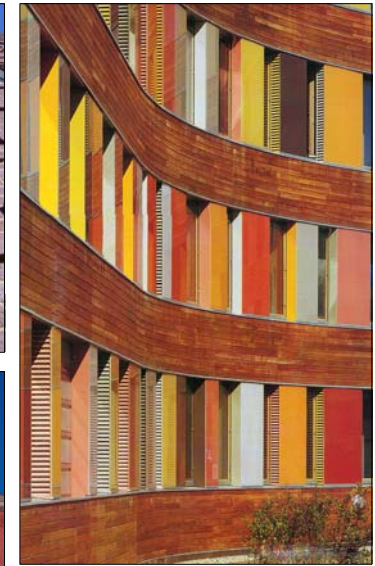

7. Scale, Proportions and Exterior Appearance of Buildings



7.3. Height, Building, Massing and Organization.

- 7.3.1. The height of new buildings should reflect the height of adjacent buildings to avoid creating a gap in the streetscape, whether by being constructed to the same height as an adjacent building, or by use of complementary horizontal design elements. When designing the façade, neighboring window sill lines and sign lines should be extended onto the façade of the new building.
- 7.3.2. New buildings should reflect and reinforce the scale, massing, proportions, rhythm, and attention to detailing established by the historic and significant buildings in Downtown Brockton.
- 7.3.3. Front building setbacks for new construction should be located within five (5) linear feet of the front setbacks of neighboring buildings.
- 7.3.4. In general, new buildings in the District should be set right on the Sidewalk. A new building may have an inconsistent setback from neighboring buildings if the front setback is to be used for a well-landscaped public space or if the front setbacks of buildings on either side of the new building are greater than ten (10) linear feet. Where differing front setbacks are approved, design elements such as a wall, fencing or landscaping of a minimum height of three (3) feet should be used to reinforce the street line.
- 7.3.5. As required by the District Ordinance, the maximum front setback for new construction in the DBSGOD is ten (10) feet.

7. Scale, Proportions and Exterior Appearance of Buildings



These buildings are of varying styles, though they complement each other. These buildings respect cornice lines, façade modules, and the rhythms and proportions of the streetscape.



When renovating buildings with blank walls, create improved streetscape with windows and doors.

- 7.3.6. Windows, wall panels, pilasters, building bays and storefronts should be carried across windowless walls to relieve blank, uninteresting surfaces.
- 7.3.7. Side and rear facades should be articulate in a manner compatible with the design of the front façade. Blank wall surfaces greater than thirty (30) feet are prohibited on walls that are visible from streets or other public areas.

7. Scale, Proportions and Exterior Appearance of Buildings

7.4. Building Façades

- 7.4.1. A selection of architectural details such as vertical and horizontal recesses and projections, changes in height, floor levels, roof forms, parapets, cornice treatments, belt courses, pilasters, window reveals, and forms, and color as appropriate to each site should be used to create shadows and texture and add to the character of a building.
- 7.4.2. Any side of the building that has frontage on a sidewalk or street shall include windows, doors, or other signs of human occupancy, such as porches or balconies.
- 7.4.3. Building design for multi-story buildings should create or maintain a visual distinction between upper and lower floors. In historic Downtown Brockton, storefronts with large windows were on the first floor and residences with smaller windows were on the second floor. Second stories should maintain this distinction whether or not they are residential in use.
- 7.4.4. Building frontage should incorporate recessed entries, recessed or projecting bays, expression of architectural or structural modules and detail, and/or variations such as surface relief, expressed joints and details, color and texture. Recesses should be a minimum of 2 feet deep.
- 7.4.5. Buildings more than forty (40) feet wide shall be broken down into a series of smaller elements or “bays” – to evoke the rhythm of historic shop fronts and mixed-use town centers, add visual character and maintain the pedestrian scale of the streetscape. No uninterrupted length of any façade shall be permitted to exceed 40% of the façade’s total length, or forty (40) horizontal feet, whichever is less, without incorporating at least one of the following design elements: color change, material change, or texture change;

and at least one of the following design elements: architectural projections or recesses, trellises, balconies, or windows.

- 7.4.6. Vertical divisions of ground and upper floors should be consistent across a building frontage. Major horizontal elements of adjacent buildings and storefronts should align. In order to modulate their scale, multi-story buildings shall articulate the base, middle, and top, separated by cornices, string cornices, step-backs or other articulating features..
- 7.4.7. Proposals for new building construction that use a particular historical style should utilize accurate elements of that style.
- 7.4.8. Exposed foundation walls shall be minimized.
- 7.4.9. Address numbers shall be prominently displayed and in accordance with all applicable regulations.

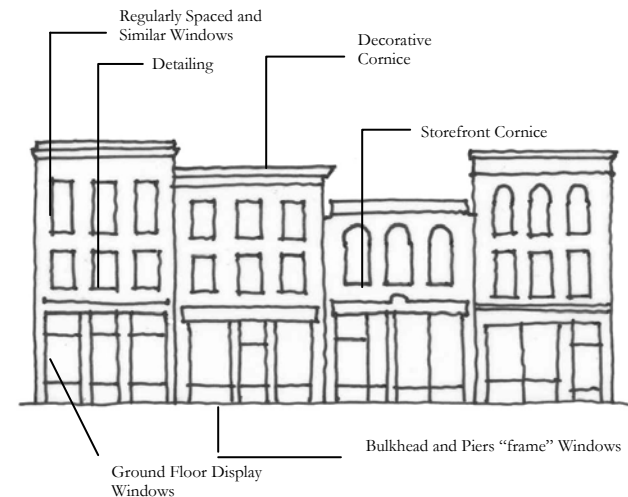

7. Scale, Proportions and Exterior Appearance of Buildings

7.5. Roofs

- 7.5.1. Roof forms should complement the principal building in terms of style, detailing, and materials. Roof lines of buildings in the District constructed prior to 1940 are acceptable precedents in the selection of proposed roof forms.
- 7.5.2. Mechanical equipment, including metal chimneys, and elevator penthouses at grade, attached to, or on the roof of a building, shall be screened from view from streets; or they should be integrated into the overall design of the building by use of materials, placement, roof shape or form, or other means.

7.6. Windows and Doorways

- 7.6.1. Windows shall be inset a minimum of three (3) inches from the exterior wall surface to add visual relief to the wall.
- 7.6.2. In general, all windows should be taller than they are wide. This is true of windows on the first as well as upper floors.
- 7.6.3. Windows on top floors should not be larger than windows on the first floor.
- 7.6.4. Windows on the top and bottom floors should align vertically and be consistent in proportion, shape, and style.
- 7.6.5. Building entrances should be prominent and easy to identify.
- 7.6.6. Recessed doorways are preferred, in order to break up the building façade, provide a welcoming space, and provide protection from sun and rain. Where a recessed doorway is not used, an awning can have a similar effect. Adequate lighting for the doorway shall be provided at night.
- 7.6.7. Doorways to upper floors shall be visually separated from street-level shop entries, and doorway location and design

should seek to minimize confusion over which doorway belongs to which business.



7. Scale, Proportions and Exterior Appearance of Buildings

7.7. *Location of Building and Garage Entrances.*

- 7.7.1. Building and garage entrances shall be sited to minimize the impact of vehicular turning movements on safe and efficient movement of vehicles, pedestrians, and cyclists within vehicular rights-of-way. New curb cuts shall not be located within fifty (50) linear feet, measured on center, from nearby vehicular intersections.
- 7.7.2. Building entrances shall provide direct access to sidewalks or Paths to emphasize pedestrian ingress and egress as opposed to accommodating vehicles.

7.8. *Service and Loading Areas.*

- 7.8.1. Service and Loading Areas shall be screened from streets and abutting properties to the greatest extent possible through the provision of architectural screening, landscaping, and fencing. Chain link fencing is not acceptable for screening purposes
- 7.8.2. Service and Loading Areas shall not face directly an open space or public street.
- 7.8.3. Trash receptacles should be located and designed for ease of trash service to the site. Trash receptacles may be located in the garage of buildings or in free-standing trash houses. Trash houses shall be located and architecturally designed to minimize their aesthetic impacts.
- 7.8.4. Service and Loading Areas in proximity to the Salisbury River shall be screened such that they are not visible from the water's edge.



8. Building Forms

The following section includes Building Forms for each of the allowable types of residential and mixed-use Development Projects within the District.

- 8.1. These Building Forms define regulatory Standards for Compliance and Guiding Principles for the various types of allowable uses.
 - 8.1.1. Where noted, specific requirements may apply in one Sub-District that may not be applicable in another Sub-District.
 - 8.1.2. The Building Forms included here are not exhaustive, and Development Projects may be approved that do not adhere to non-dimensional components of the Building Form corresponding to the proposed type of Development Project. An Applicant has the option to include within an Application for Site Plan Approval an alternate Building Form or Forms that set out the design objectives for the proposed Development Project. If Building Forms are approved by the Planning Board that vary from the Building Forms here, these forms shall become permitted on an As-of-right basis for subsequent Development Projects within the District.
 - 8.1.3. Nothing in this section is intended to exempt Development Projects from the specific dimensional requirements governing building bulk, height, setbacks and density included herein or in the District Ordinance.



8.2 Single-Family 35'

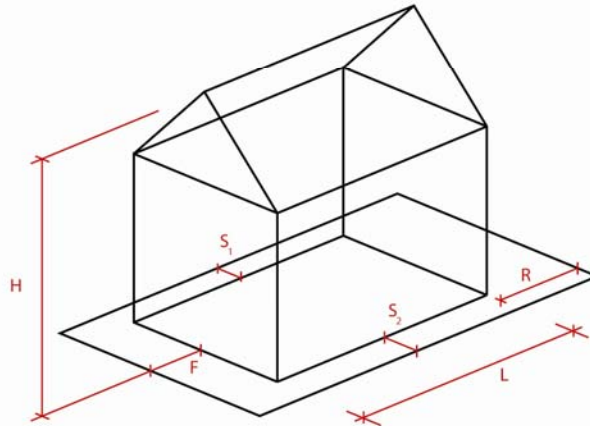
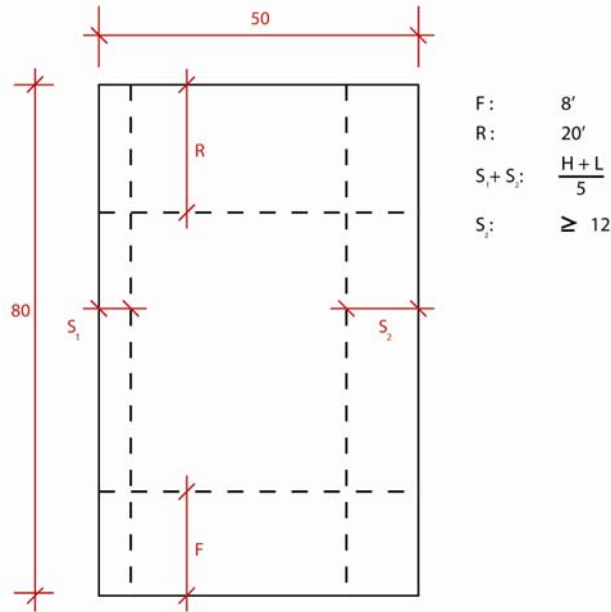

8.2.1. *Single Family Dwelling Units are an Allowable Use in the following Sub-Districts:*

	Max. Height
Arts-Culture	35'
Corcoran	35'
Downtown Core	35'
Ralsco	35'
Star-Market	35'

8.2.2. *Additional Single Family Detached Dwelling Units Standards*

- 8.2.2.1. Recommended minimum lot dimensions and building setbacks are shown in the illustration on the left.
- 8.2.2.2. New single-family dwelling units should include front porches or stoops located at street level to allow outdoor seating and to provide a direct connection to adjacent streets.
- 8.2.2.3. The ground floor of new Single-Family Detached Dwelling Units shall be raised above grade by three or four feet to allow for separation between the street and the home, and to ensure privacy for those dwelling units with first floor windows.
- 8.2.2.4. Front yards: New construction of Single-Family Detached Dwelling Units shall include a front yard in order to create a transition space between the public domain and the privacy of the home.
- 8.2.2.5. Garages shall have a front setback at least ten (10) feet greater than the building's front setback.

8.2 Single-Family 35'



simple additive forms

high depth to width ratio

gable ends

entrance on front facade with articulated front stoop / porch

vertically proportioned windows

raised ground floor

side parking

SF35 single family detached (35')

8.3 Two-Family 35'

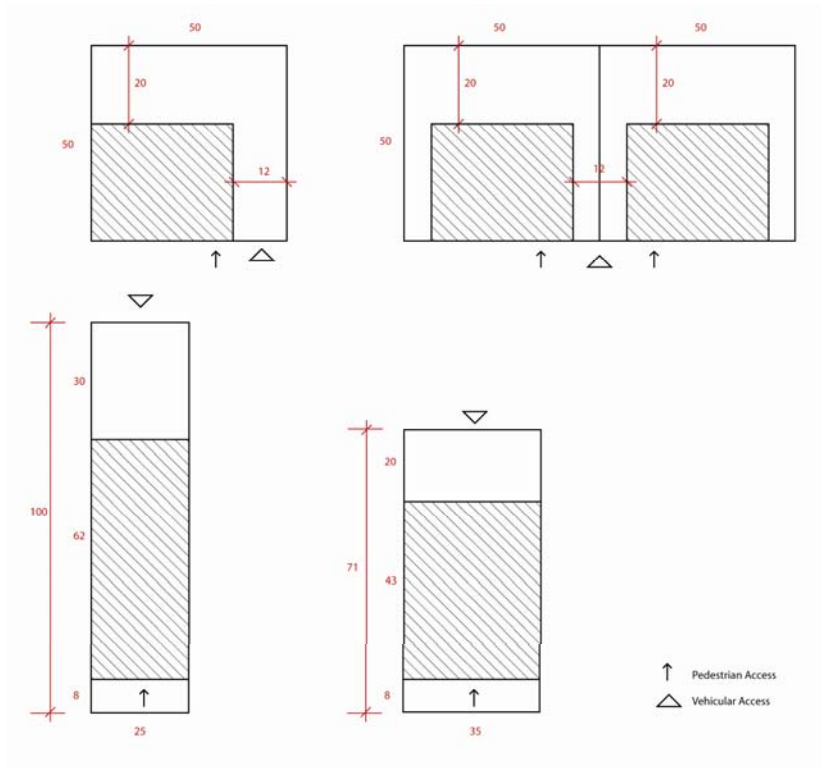

8.3.1. *Two-Family Dwelling Units are an Allowable Use in the following Sub-District:*

	Max. Height
Arts-Culture	45'
Corcoran	45'
Downtown Core	45'
Ralsco	35'
Star-Market	35'

8.3.2. *Additional Two-Family Dwelling Units Standards*

8.3.2.1. The ground floor of new Two-Family Dwelling Units shall be raised above grade by three or four feet to allow for separation between the street and the home, and to ensure privacy for those dwelling units with first floor windows.

8.3.2.2. Two-Family Dwelling Units may include internal parking at grade.

8.3.3. *Setbacks*

8.3.3.1. Two family Dwelling Units shall have combined side setbacks of 8 to 12 feet. This may be satisfied with a 8 to 12 foot setback on one side (and a zero foot setback on the opposite side). Alternatively, the setback may be divided between the two sides. In the event that setbacks are divided, neighboring lots should be planned to allow for a shared driveway in between the homes, or shall provide direct vehicular access to the rear of the lot.



8.3 Two-Family 35'



simple construction

steep roof pitch for habitable
attic

vertically oriented double-
hung windows

articulated facade /
bay window

raised front entrance

front / side setback

narrow street frontage

2F35 2-family (35')

8.4 Three-Family 35' - 45'

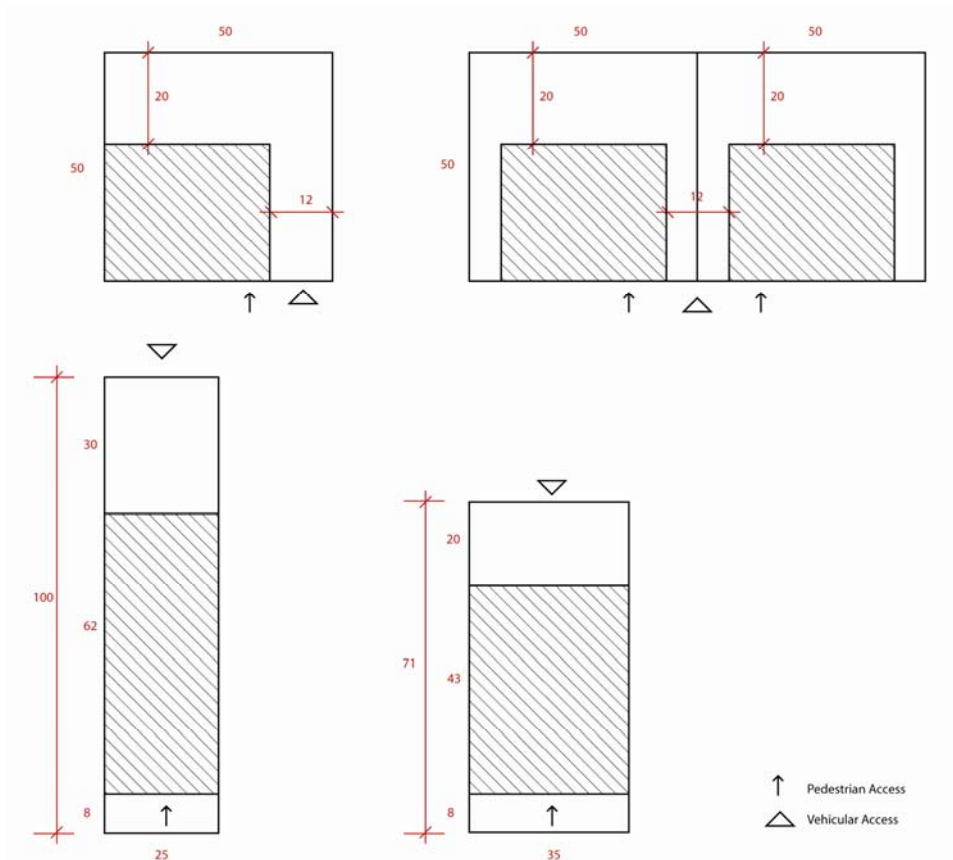

8.4.1. *Three-Family Dwelling Units are an Allowable Use in the following Sub-Districts*

	Max. Height
Arts-Culture	45'
Corcoran	45'
Downtown Core	45'
Ralsco	35'
Star-Market	35'

8.4.2. *Additional Three-Family Dwelling Units Standards*

8.4.2.1. The ground floor of new Three-Family residential buildings shall be raised above grade by three or four feet to allow for separation between the street and the home, and to ensure privacy for those dwelling units with first floor windows.

8.4.2.2. Three-Family buildings may include internal parking at grade if access to the parking space(s) is provided from the side or rear of the building. Garages located internal to Three-Family Dwelling Units shall be limited in width to one parking bay, but may include space for more than one vehicle parked end to end.



8.4 Three-Family 35' - 45'



characteristic New England
urban housing

simple construction

efficient floor to envelope
ratio

bay windows

stacked circulation

street-facing decks

raised front entrance

front / side setback

3F35 3-family (35'+)

8.5 Multi-Family 45'+

8.5.1. *Multi-Family Dwelling Units are an Allowable Use in the following Sub-Districts:*

	Max. Height
Arts-Culture	45'
Corcoran	45'
Downtown Core	85'

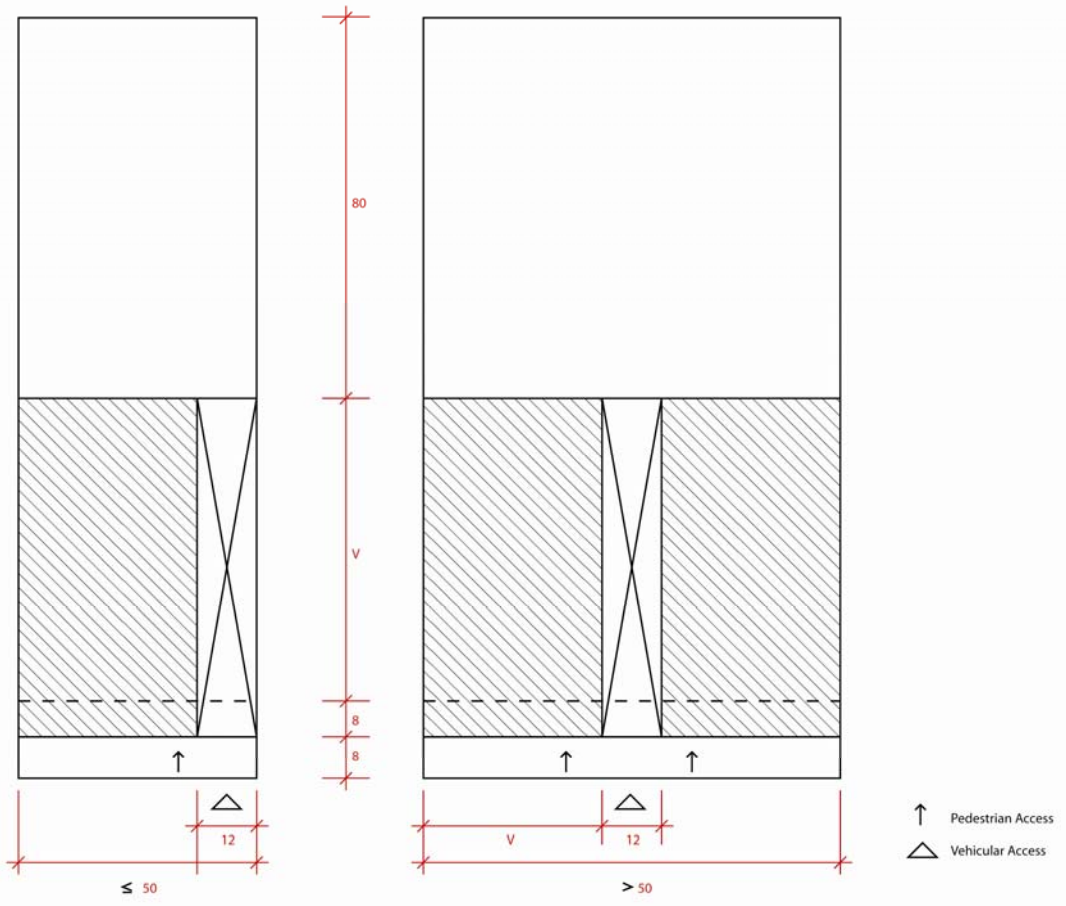

8.5 Multi-Family 45'+



MF45

multi-family (45')

8.5 Multi-Family 45'+



8.5.2. *Additional Multi-Family Dwelling Units Standards*

- 8.5.2.1. The ground floor of new Multi-Family residential buildings shall be raised above grade by at least three or four feet to allow for separation between the street and the home, and to ensure privacy for those dwelling units with first floor windows.
- 8.5.2.2. *Proximity to public space and pedestrian and bicycle network.* Residential buildings shall be sited to allow for front steps, balconies, and porches with access to adjacent public space or pedestrian and bicycle paths.
- 8.5.2.3. Where proposed residential buildings are not located adjacent to public spaces, site design should include new public and/or private open spaces or yards accessible to building residents.

8.5 Multi-Family 45'+

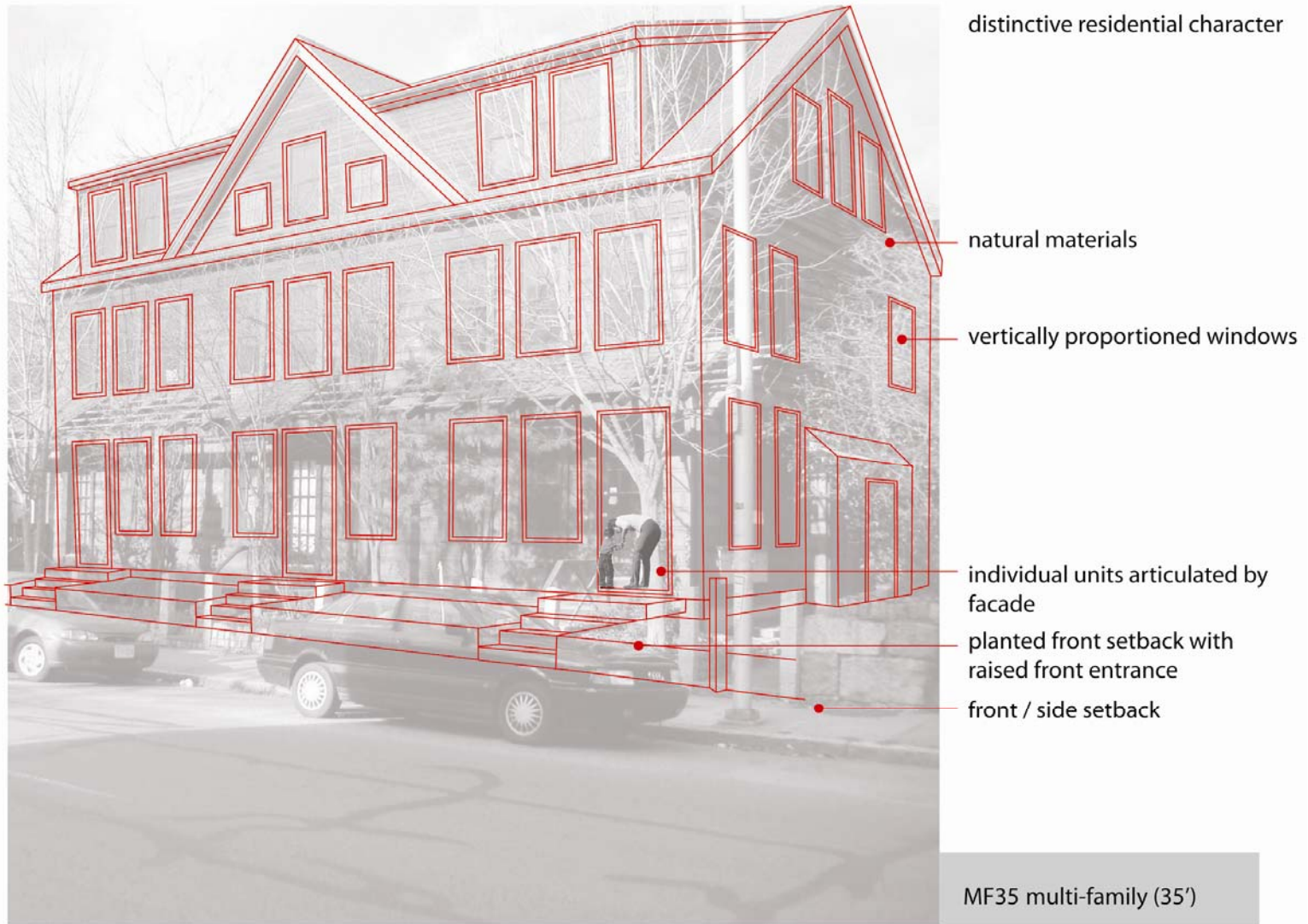

8.6 Mixed-Use 45'+



8.6.1. *Mixed-Use Development is an Allowable Use in the following Sub-Districts:*

	Max. Height
Arts-Culture	45'
Corcoran	45'
Downtown Core	85'
Star-Market	45'

8.6.2. *Additional Mixed-Use Development Standards*

- 8.6.2.1. In Mixed-Use buildings, retail uses shall be located in ground floor levels and shall be accessible to pedestrians from Sidewalks. However, retail uses may include a second story if the overall non-residential development within the Development Project does not exceed the maximum allowable percentage (50%) specified in the District Ordinance.
- 8.6.2.2. Street level frontage adjacent to public streets or open spaces should be primarily devoted to entrances, shop windows, or other displays.
- 8.6.2.3. All mixed-use buildings shall have a principal façade and entry (with operable doors) facing a public street or open space.
- 8.6.2.4. Retail and first floor commercial windows shall allow two-way visibility in order to enhance safety on the street and create a visually interesting pedestrian environment. The use of dark tinted glass or reflective glass is prohibited.

8.6 Mixed-Use 45' +



strong cornice line

bay window variations
in elevation

repetition of similar facade
elements

first floor change of material
ground floor retail with higher
story heights

MU45 mixed-use (45')

8.6 Mixed-Use 45' +

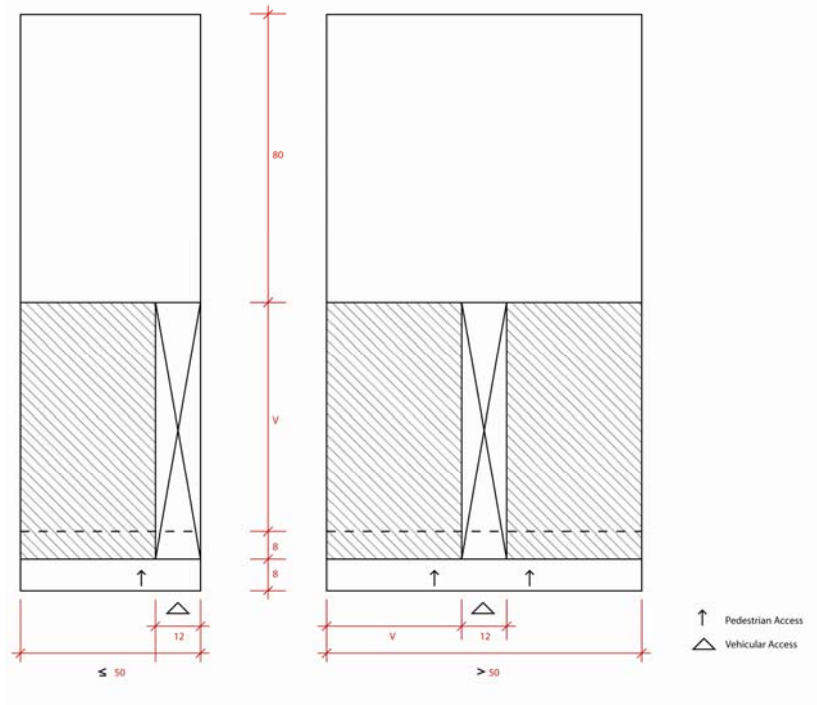

Storefront

- 8.6.2.5. Retail portions of mixed-use buildings should include a minimum of 30% glazed windows along the store frontage.
- 8.6.2.6. Storefronts should remain unshuttered at night and should provide clear views of interior spaces lit from within. Where used, security grilles and tracks shall be carefully integrated into storefront design and shall be concealed when not in use. Solid roll-down grilles are not permitted.
- 8.6.2.7. New development should maintain a regular rhythm of storefronts along a block with entrances every twenty-five to fifty feet (25' to 50'). Continuous lengths of flat walls are not permitted.
- 8.6.2.8. Except for recessed entries, arcades, and similar features that provide benefit for pedestrians, storefronts in mixed-use buildings should be built to the property line, and shall in no case have a front setback greater than ten (10) feet. Recessed portions should reinforce the streetline.
- 8.6.2.9. Entries and doors should be well-detailed. Doors should match the materials, design and character of the display window framing.
- 8.6.2.10. Retail entries shall be accessible from at least one sidewalk.



8.6 Mixed-Use 45' +



penthouse setback

individual units identified with balconies

simple steel frame construction

simple massing accommodates variable ground floor forms

bay articulation strengthens relationship with pedestrian scale at street level

ground level retail

no front or side setback

opportunity for mixed use (e.g. cultural facility)

MU60 mixed use (60'+)

8.7 Renovation



8.7.1. *Additional Standards*

- 8.7.1.1. Conversion of significant or historic structures to other uses shall be done with sensitivity to the structure, with as little deviation as possible from the design of the original building.
- 8.7.1.2. All renovations shall, to the maximum extent feasible, maintain the scale and proportion of the original building elements including roof shape and height, structural framework, cornice, sign band, window size and symmetry, and decorative elements.
- 8.7.1.3. Architectural elements present on existing buildings shall be incorporated when designing additions or renovations.
- 8.7.1.4. On a building proposed for renovation pursuant to the District Ordinance, the covering or removal of original façade elements (columns, pilasters, fenestration, arches, lintels, decorative elements) is prohibited. Proposals for a façade renovation that uses a particular historical style should utilize accurate elements or materials of that style.

8.7 Renovation

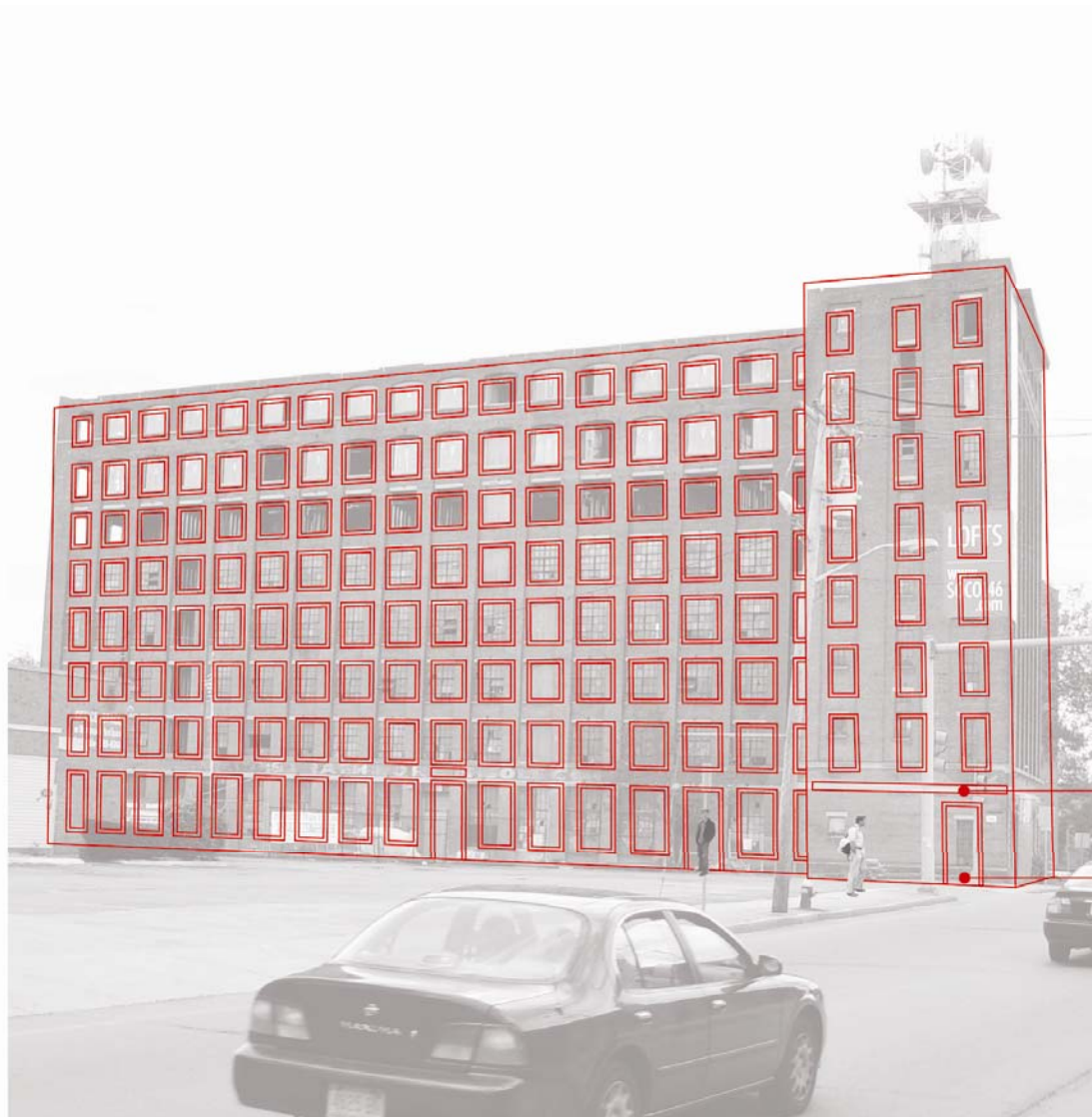

adaptive re-use of former
mill / loft building

individual units subsumed to
overall massing

parking and landscaping critical
for residential conversion

identify / articulate main
entrance(s) for residential units

no front or side setbacks

R renovation

8.7 Renovation



- 8.7.1.5. On a building proposed for renovation pursuant to the District Ordinance, distinctive architectural features should be restored, and elements that cover up original details should be removed. Architectural features that are important to preserve include but are not limited to bay windows, transom windows, columns on the façade, the cornice, sign band, and other details including medallions and decorative panels. Architectural features that should be removed include: siding that covers original brick, metal or wood siding and detail; and shed roofs or false fronts over first floor shop fronts, which may be replaced with awnings or traditional building sign bands.

Roofs

- 8.7.1.6. Roofs. Original copper flashing on roofs and cornices shall be restored where feasible.



8.7 Renovation



adaptive re-use of former commercial building

maintain distinctive architectural characteristics

landscaping and parking necessary for residential conversion

no front setback

R renovation

9.1 Placement, Alignment, Width, and Grade of Streets and Sidewalks

- 9.1.1. New Development Projects within the District should enhance the existing Pedestrian Network of Sidewalks and Paths. Within their Application for Site Plan Approval, Applicants shall include a written statement of whether and to what extent the proposed Development Project achieves this objective.
- 9.1.2. Where the proposed Development Project abuts streets that lack Sidewalks, or where Sidewalks abutting the proposed Development Project do not meet applicable standards, Applications should propose a plan for pedestrian walks and bicycle paths as appropriate to the neighborhood. Additions to the Pedestrian Network may include a combination of Sidewalks, Paths and Pass-Through Walkways.
- 9.1.3. All new Sidewalks, Paths and Pass-Through Walkways shall be designed and constructed to be accessible to the handicapped in accordance with applicable laws including the Americans with Disabilities Act and the Rules and Regulations of the Massachusetts Architectural Access Board.
- 9.1.4. Where existing Sidewalks within rights-of-way abutting proposed Development Projects are cracked, broken or uneven, Applicants are strongly encouraged to propose improvements to said Sidewalks.
- 9.1.5. Where provided, Sidewalks and Paths should connect proposed buildings with parking intended to serve the use.
- 9.1.6. Where pedestrian connections cross a street, a crosswalk shall delineate the pedestrian connection with painted striping or, where approved by the Department of Public Works, alternate building materials to improve pedestrian visibility. Traffic calming measures such as bump outs, raised intersections, and speed bumps may be installed with the approval of the Department of Public Works.

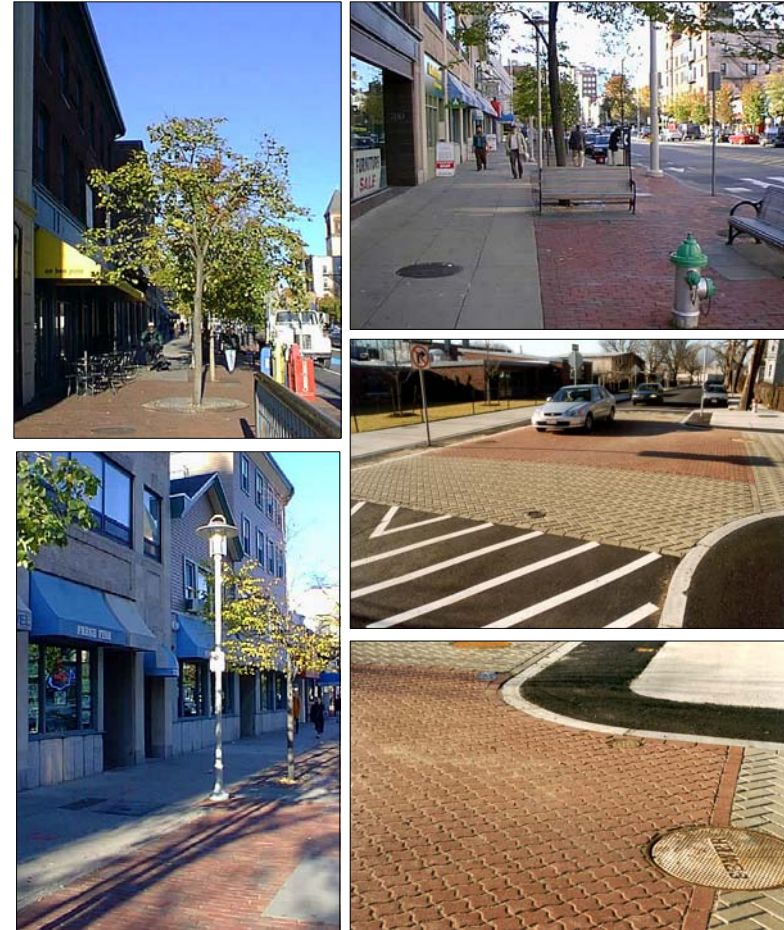

9.1 Placement, Alignment, Width, and Grade of Streets and Sidewalks

9.1.7. Sidewalks

9.1.7.1. Sidewalk material shall include a mixture of masonry pavers, concrete, and/or bituminous concrete to provide visual interest and to delineate sidewalk areas that may be used for other functions such as outdoor seating areas.

9.1.7.2. Sidewalks should, in coordination with their associated street, include a variety of landscape elements including trees and tree grates, planters, and seasonal plantings. Landscape features should be selected that enhance the pedestrian environment such as plazas, sitting areas, and outdoor cafes.

9.1.8. *Paths.* Paths may be provided instead of Sidewalks where doing so results in construction that is more sensitive to the natural or proposed topography, and where the incorporation of meandering layout results in more interesting site design without loss of functionality as a Pedestrian Way. Where parcels abut the Salisbury River, proposed Paths should be coordinated with the Greening of the Salisbury public initiative through the Office of the City Planner.



9.1 Placement, Alignment, Width, and Grade of Streets and Sidewalks

9.1.9. *Pass-Through Walkways.* Pass-Through Walkways may be incorporated into site design to provide mid-block pedestrian access between streets, or to access parking areas. Pass-Through Walkways should be constructed of a mixture of masonry pavers and concrete, or other materials that complement the existing Sidewalks that they adjoin. These areas should be designed for pedestrian use and shall provide adequate lighting for nighttime safety. Pass-Through Walkways should include bollards, vertical curbing or other means to prevent access by motorized vehicles.



9.1.10. *Curb Cuts*

9.1.10.1. Curb cuts should be minimized on streets where on-street parking is permitted to maximize space for parking.

9.1.10.2. Within the Star Market and Ralsco Sub-Districts, multiple residential driveways on Warren Avenue shall not be permitted provided, however, that a single curb cut may be permitted for an access drive that serves multiple residential Dwelling Units. Where residential uses front on Warren Avenue, access to parking should be provided from internal driveways or alleys to the maximum extent practical. In the Ralsco Sub-District, residential driveways may be permitted on Bartlett Street.

9.1.10.3. Residential driveways are prohibited on Pleasant Street or Warren Avenue; where residential uses front on these public ways, access to parking should be provided from internal driveways or alleys to the maximum extent practical.



9.2 Exterior Signs

- 9.2.1. The Planning Board may allow signs of such size and height as appropriate for identification and safety in relation to a proposed use and in relation to the intensity, buffers, and setbacks of such use. Each Mixed-Use Development Project in the District may include a Primary Storefront Sign, a Storefront Cantilevered Sign, a Display Window Sign, and an Awning or some combination thereof.
- 9.2.2. The size, location, design, color, texture, lighting and materials of signs and advertising devices should complement significant architectural features of existing and proposed buildings and structures and with surrounding properties. Signs should be placed on buildings in a manner consistent with architectural details and should not conflict with elements such as cornices, arches, lintels, pediments, windows, pilasters, etc.
- 9.2.3. Signs in the District shall be designed primarily to be visible to pedestrians or slow moving traffic. There are no “high speed” roadways passing through commercial areas where signage needs to be oriented to fast moving vehicles.
- 9.2.4. Awnings. If awnings are used to provide signage, they should be standardized by height above grade, type, size, materials, colors, illumination and method of installation across the building façade and within the block to the largest extent practical.
- 9.2.5. Signage should have geometric shapes with two to three colors to complement the colors of the retail building. Internally lit signs and flashing signs are prohibited.

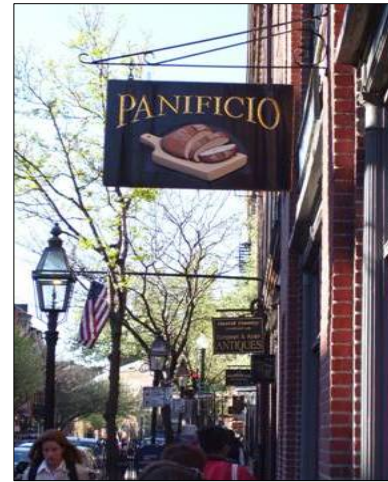

9.2 Exterior Signs

9.2.6. Primary Storefront Sign.

- 9.2.6.1. A Primary Storefront Sign shall be located within a sign band approximately 8 to 15 feet above finish floor. When a tenant has elevations fronting on different sides of a building, the tenant may have a Primary Storefront Sign on each façade.
- 9.2.6.2. The total sign area for the Primary Storefront Sign shall not contain more than two square feet of sign area for each linear foot of storefront. Sign area shall be calculated by creating a box around the main body of the primary sign. The store leaseline width multiplied by two square feet equals the maximum sign area in square feet, and may not exceed 80 square feet.

9.2.7. Storefront Cantilevered Sign.

- 9.2.7.1. Each tenant will be allowed to construct and install a Storefront Cantilevered Sign not in excess of eight (8) square feet as measured on one face of the sign. Any such Storefront Cantilevered Sign shall not count toward the total allowable area of signage on a single façade.

9.2.7.2. A Storefront Cantilevered Sign is to be attached to tenant's storefront at a minimum 7'6" above finish floor.

9.2.7.3. Each Storefront Cantilevered Sign may be externally illuminated with two integrated lights (one light on each sign face or panel). The Storefront Cantilevered Sign may be square, round, elliptical or other shape. Complex shapes and three-dimensional letters or figures are encouraged. Formed plastic, injection molded plastic, and internally illuminated panels are prohibited.

9.2.8. Display Window Sign. Signs on the inside or outside surface of display windows may be permitted provided, however, that such signage shall not cover more than ten percent (10%) of the display window area and shall be lighted only by building illumination (white non-flashing).

9.2 Exterior Signs

- 9.2.9. Awnings. The following design standards apply.
- 9.2.9.1. Awnings shall be made of fire resistant, water repellent marine fabric (i.e., canvas) or may be constructed of metal or glass. Vinyl or vinyl-coated awning fabric will not be permitted.
 - 9.2.9.2. Patterns, graphics and stripes are encouraged. Colors should accent the building and street design.
 - 9.2.9.3. Continuous, uninterrupted awning spans are not permitted. Fixed awnings shall not span numerous bays, windows or store fronts. When determining where an awning should end, look for clues on the building. The awnings should delineate storefronts on a multi-tenant building. The Awning shall fit within each individual bay and shall not obstruct any base building mechanical louvers located above the Tenant storefronts.
 - 9.2.9.4. If the awnings include a valance, it shall be provided with concealed weights so as to prevent the valance from excessive movement in high winds.
 - 9.2.9.5. Internally illuminated awnings are not permitted except that down lighting that is intended to illuminate the Sidewalk may be provided under the awning. All lighting under a canopy shall be cutoff or recessed, with no lens dropping below the horizontal plane of the canopy.
 - 9.2.9.6. A screenprinted tenant logo will be permitted on the awning slope if the design is complementary to the overall storefront design. The tenant name may be screenprinted on the 8” valance in the tenant’s typeface and color in letters no larger than 5” tall.
 - 9.2.9.7. Any framing members and armatures/brackets should match the material and color of the storefront unless a different material enhances the overall design intent.
 - 9.2.10. Prohibited Sign Types. The following is a list of prohibited sign types:
 - 9.2.10.1. Exposed neon expressed in a simple single or double stroke application.
 - 9.2.10.2. Registration “R” mark or trademark “TM” symbols, affixed either to sign or sign band.
 - 9.2.10.3. Signs employing luminous vacuum formed plastic letters.
 - 9.2.10.4. Signs employing unedged or uncapped plastic logos or letters with no returns and exposed fastenings.
 - 9.2.10.5. Signs or lights that move, flash, or make noise. Such shall include commercial balloon devices, high powered search lights, and L.E.D. signage (Indicators of time or temperature may move).
 - 9.2.10.6. Box style cabinet signs or “can signs” with illuminated, translucent background and silhouette, translucent or acrylic letters.
 - 9.2.10.7. Signs utilizing paper, cardboard, Styrofoam signs, stickers or decals hung around, on or behind storefronts applied to or located behind the storefront glazing.

9.2 Exterior Signs

- 9.2.10.8. No advertising placards, banners, pennants, names, insignia, trademarks, or other descriptive or promotional material may be affixed or maintained on windows, glass fixtures and equipment or any other area of the storefront, including credit card signs.
- 9.2.10.9. Any imitation of official traffic signs or signals or use of such words as “stop,” “look,” “danger,” “go slow”, “caution,” or “warning” are prohibited.
- 9.2.10.10. No red or green lights or any lighting effect utilizing such colors used on any sign if, in the opinion of the Chief of Police, such light or lighting would create a hazard to the operation of motor vehicles.
- 9.2.10.11. Portable signs with or without replaceable letters which may be moved from one location to another.
- 9.2.11. Address Signs.
- 9.2.11.1. Primary Address Sign. Each non-residential tenant shall display the suite number on their façade to allow for identification of the premises. The numerals are to be applied on the interior of the storefront glazing in five-inch high numbers with no less than one-half inch stroke.
- 9.2.11.2. Final Address Sign design is subject to the approval of the Fire Department
- 9.2.11.3. Secondary Address Sign. If tenant has a non-customer door for receiving merchandise, tenant shall place only its suite number on that door. Numerals shall be mounted to the exterior face of the door and shall be comprised of five-inch high numbers with no less than one-half inch stroke. Where more than one tenant uses the same door, each suite number may be applied.

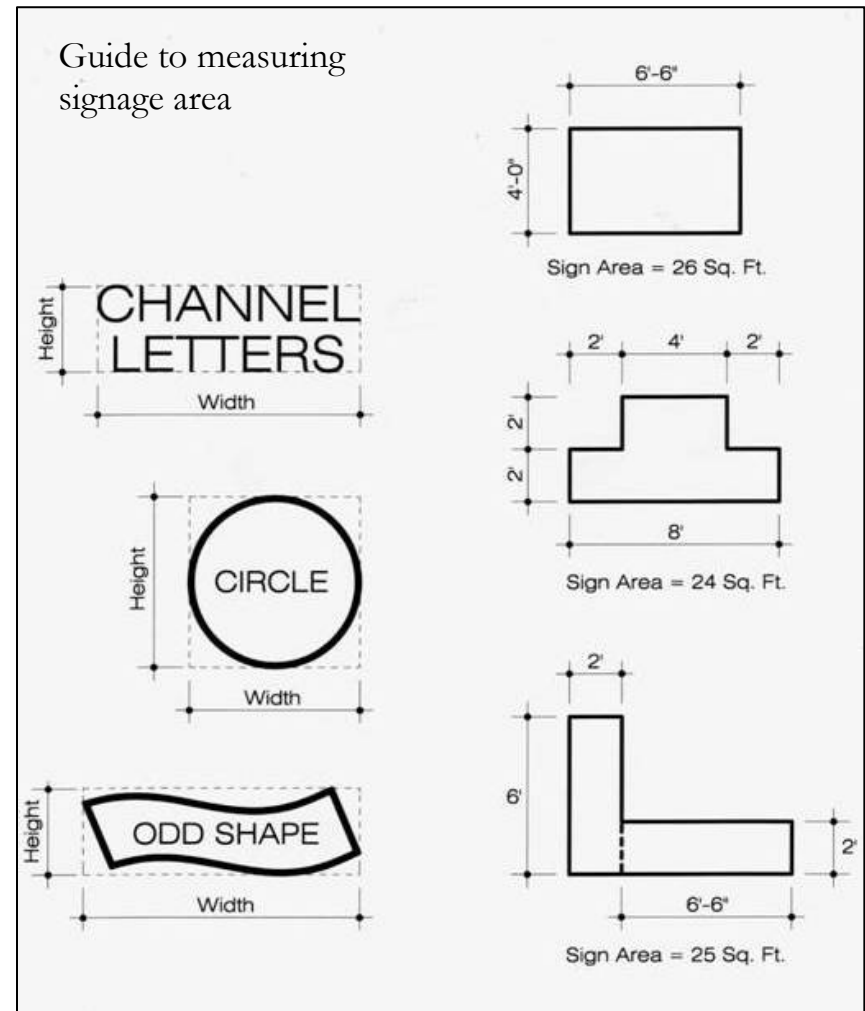

9.3 Lighting

- 9.3.1. For reasons of safety and the reduction of light trespass, glare and light pollution, all outdoor lighting in the District shall comply with the following provision: Direct light emitted by exterior luminaire shall not emit directly by a lamp, off a reflector, or through a refractor above a horizontal plane (90 degrees) through the fixture's lowest light-emitting part.
- 9.3.2. Uplighting is only permitted when used as follows:
- 9.3.2.1. To light a primary entrance, when the lighting fixture is wall-mounted under an architectural element (e.g., roofs over walkways/entries or overhanging, nontranslucent eaves) so this uplight is captured.
- 9.3.2.2. To light local, state, or national flags, when no more than two light fixtures per flagpole are used, with an equivalent total lumen maximum of a 150 watt bulb (incandescent). The fixtures must be shielded such that the lamp is not visible outside a fifteen-foot radius. It is preferred that all flags be lowered at sunset.
- 9.3.3. The height of a light fixture shall be measured from the ground to the light emitting flat glass of the luminaire; pole height may be higher than this light-emitting height. Maximum height requirements for each area within the District are as follows:
- 9.3.4. Spacing of streetlights should provide for uniformity of light, with the distance depending on the minimum illumination levels required.
- 9.3.5. If the Sidewalk includes street trees, locate streetlights between the trees so that the tree canopy does not interfere with illumination coverage.
- 9.3.6. Street poles and lighting fixtures shall be dark in color to reduce light reflectivity.
- 9.3.7. Light fixtures may include an option for brackets to attach banners and other temporary graphic elements.
- 9.3.8. All light fixtures shall emit a steady and constant light and shall not emit a flashing or irregular light, unless specifically required by Federal, State, or municipal authorities.
- 9.3.9. Blinking, flashing, moving, revolving, scintillating, flickering, changing intensity and changing color lights are prohibited except for temporary holiday displays, lighting for public safety or traffic control, or lighting required by the FAA for air traffic control and warning purposes.
- 9.3.10. *Lighting Plan.* Wherever outside lighting is proposed, every application for Site Plan Approval shall be accompanied by a lighting plan which shall show:
- 9.3.10.1. The location and type of any outdoor lighting Luminaires, including the height of the Luminaire.
- 9.3.10.2. The Luminaire manufacturer's specification data, including lumen output and photometric data showing cutoff angles.
- 9.3.10.3. The type of lamp such as: metal halide, compact fluorescent, high-pressure sodium, etc.
- 9.3.10.4. A photometric plan showing the intensity of illumination at ground level, expressed in footcandles

Lighting

Commercial, Mixed Use
Neighborhood



A clean distinctive modern light. Downward focus on Sidewalk and minimal light spillage. Suitable for commercial and mixed-use neighborhoods.



Commercial, Mixed Use
Neighborhood



Clean modern street light with horizontal and downward photometrics. Suitable for shopping/ pedestrian commercial and mixed-uses

Cultural, Retail Neighborhoods and Parks



Art Nouveau light standard, open bulb downlight with some lateral spillage



Taller bollard acts as marker for boundary or path. Significant glare detracts from this otherwise attractive design.

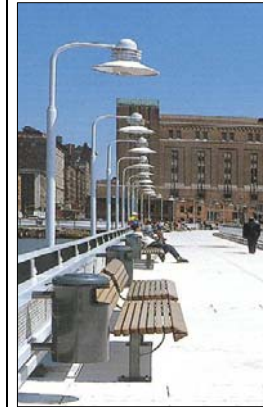

Residential Neighborhoods and Parks



Modern light standard, open bulb downlight with minimal lateral spillage



Lighting

Mixed Use and Residential Neighborhood	Residential Neighborhood	Residential and Mixed Use Neighborhoods	Street Lighting (Main Streets)
 <p data-bbox="111 1015 537 1112">Effective downlighter with minimum glare and spillage. Suitable for neighborhood streets.</p>	 <p data-bbox="579 1047 951 1177">Distinctive design but with considerable glare and spillage and inefficient luminance on the ground plane</p>	 <p data-bbox="984 800 1356 995">Standard bollard design between 30" to 42" height delineates and illuminates paths and boundaries with minimal glare and light spillage. Suitable for neighborhoods, parks etc</p>	 <p data-bbox="1390 711 1917 841">30-foot light standard suitable for primary distributor street. Otherwise acceptable traditional design incorporates lamp with high glare and spillage characteristics.</p>  <p data-bbox="1547 1036 1902 1230">30-foot light standard more suitable for highways and arterial roads. Not suitable for neighborhood because of glare and typical yellow / orange sodium lighting.</p>

9.3 Lighting

9.3.11. Prohibited light sources:

- 9.3.11.1.1. Mercury vapor, low pressure sodium and quartz lamps. For the purposes of these Design Standards, quartz lamps shall not be considered an incandescent light source.
- 9.3.11.1.2. Laser source light. The use of laser source light or any similar high-intensity light for outdoor advertising, when projected above the horizontal, is prohibited.
- 9.3.11.1.3. Searchlights. The operation of searchlights for advertising purposes is prohibited.
- 9.3.11.1.4. Cobra head light fixtures are prohibited.
- 9.3.11.2. Metal halide lighting. All outdoor light fixtures utilizing a metal halide lamp or lamps shall be shielded and filtered. Filtering using quartz glass does not meet this requirement. *Light Levels.* Light levels shall meet or exceed the minimum design guidelines defined by the Illuminating Engineering Society of North America (IESNA).
- 9.3.11.3. Light levels shall be designed to meet a ratio of maximum to minimum footcandle (FC) levels, with

required minimum levels at the boundaries of the District. Specifically, light levels shall be designed to the following standards:

- 9.3.11.3.1. When commercial facilities are closed:
 - Minimum of 0.2 FC
 - Maximum to minimum ratio of FC in the District of 20:1

- 9.3.11.3.2. When commercial facilities are open:
 - Minimum of 0.6 FC
 - Maximum to minimum ratio of 15:1 FC in the District

- 9.3.12. Lighting should be provided for Sidewalks and Paths that link buildings with public spaces, parking areas, recreation facilities and Sidewalks on adjacent land wherever practical.
 - 9.3.12.1.

9.4 Stormwater Management

throughout the life of the system. The Operation and Maintenance Plan shall remain on file with the Approving Authority and shall be an ongoing requirement.

- 9.4.1. Stormwater management systems shall incorporate “Best Management Practices” (BMP) as prescribed by the Massachusetts Department of Environmental Protection, in addition to employing Low Impact Development (LID) strategies. BMP/LID means and methods should be carefully integrated within the site design approach with a goal of decentralizing stormwater management systems to the greatest extent practical and minimizing environmental impact of new development. The specific goals of the BMP/LID measures should be mitigation of post-development down stream impacts and achieving the highest level of water quality for all stormwater runoff.
- 9.4.2. Systems and the designed approach for stormwater management should include elements such as infiltration chambers, landscaped swales, vegetated rain-gardens, infiltration trenches, dry-wells, permeable pavements and other runoff controlling features that in combination serve to achieve BMP/LID goals.
- 9.4.3. All systems which deliver, treat, infiltrate, and/or discharge stormwater runoff to ground or surface waters shall be sufficiently treated and monitored to achieve all applicable effluent standards of the Brockton Board of Health, Department of Public Works, Conservation Commission and the Massachusetts Department of Environmental Protection, as applicable.
- 9.4.4. An Operation and Maintenance Plan is required at the time of application for all Development Projects. The maintenance plan shall be designed to ensure compliance with the Permit, the District Ordinance and that the Massachusetts Surface Water Quality Standards, 314, CMR 4.00 are met in all seasons and

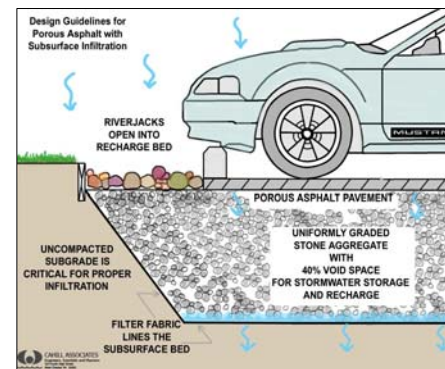

Rather than channeling rainwater into structural catch basins and pipes, bioretention cells can be designed into parking areas to improve the quality of stormwater runoff.

The use of permeable pavers will improve groundwater recharge and water quality.

All images courtesy of the Metropolitan Area Planning Council (MAPC).

9.5 Off-Street Parking

Off-Street Parking. The intent of these parking standards is to encourage a balance between pedestrian-oriented development and necessary car parking.

9.5.1. *Parking Garages*

- 9.5.1.1. Parking garages should be designed to be architectural assets to Downtown Brockton. Parking garage design should be located within the block to minimize visibility from public streets. Design should respect the historic character, and proportions, of neighboring buildings.
- 9.5.1.2. Locate parking structures underground or behind buildings where feasible.
- 9.5.1.3. Ground level parking should be screened from the sidewalk with habitable space, unless a suitable alternative is proposed. Blank walls are not permitted. Screening may include laminate uses such as retail, office, or residential and/or landscaping.
- 9.5.1.4. Garage entries shall be designed so that conflicts between vehicles and pedestrians are minimized. Vehicular entries should be clearly marked with architectural devices and/or landscaping and should be of minimum width necessary for vehicular access and egress.
- 9.5.1.5. Parking structures shall conceal views of autos from public streets and public spaces.

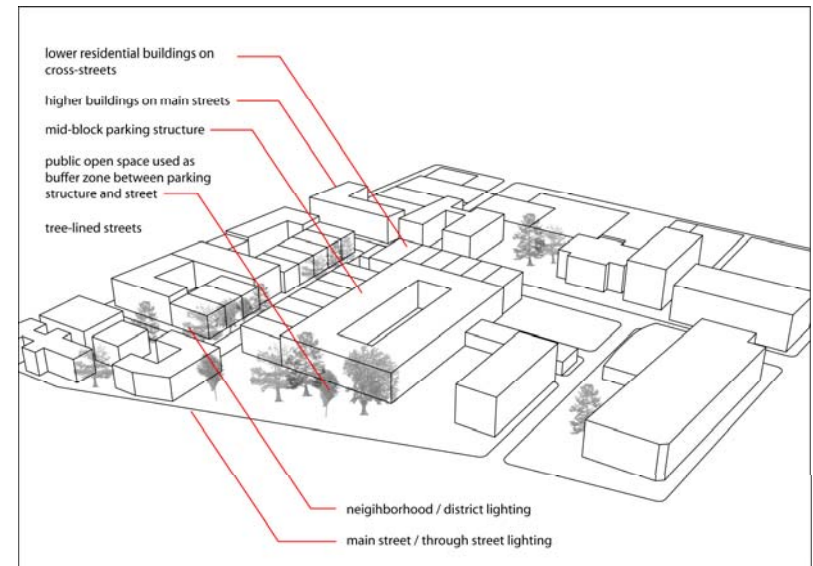

9.5 Off-Street Parking

- 9.5.1.6. Parking garages should be compatible in color, form, and quality of architectural details with adjacent buildings and development patterns in Downtown Brockton.
- 9.5.1.7. Openings to parking areas other than garage doors should be limited to those required by the Building Code for ventilation. Openings should be well above or below eye level and should be covered with visually attractive screening such as _____ to minimize the parking and its lighting from being seen from the street.
- 9.5.1.8. Signage and light sources internal to the parking structure shall not be visible from outside the parking structure. Lighting, particularly on parking decks, shall not illuminate or produce glare to adjacent properties.
- 9.5.1.9. Setbacks from the property line are permitted to accommodate landscaping and other buffer features subject to approval by the Planning Board.



Renovated buildings may include one or more level dedicated to structured parking.

9.5 Off-Street Parking

9.5.2. *Surface Parking Lots.*

9.5.2.1. Surface parking lots shall be located to the side or the rear of new buildings and such that buildings or landscaping separate parking areas from the street. Off-street parking lots shall be set back a minimum of 10 feet from property lines along public rights-of-way, excluding alleys.

9.5.2.2. If parking lots cannot be located to the rear of the property, parking lots shall be screened from the sidewalk with transparent, attractive and well-maintained cast-iron and brick fencing, plantings, or an earthen berm. Screening shall be at least 3 feet high.

9.5.2.3. Parking lots should be landscaped as follows

9.5.2.3.1. Parking lot landscaping should not have a continuous curb in all places. To allow for runoff to reach the landscaped areas.

9.5.2.3.2. Parking lot landscaping should be lower than or level with the parking lot to allow for runoff to reach the landscaped areas.

9.5.2.3.3. The use of permeable pavement is encouraged in parking lot construction to allow the infiltration of stormwater through the site.

9.5.2.4. Typical parking spaces in a parking lot shall have minimum dimensions of 9 feet x 18 feet. One hundred (100) square feet of maneuvering area shall be provided for each parking space in a lot.

9.5.2.5. Parallel parking shall have minimum dimensions of 8 feet x 22 feet.

9.5.2.6. Compact car spaces may be provided to a maximum of 20% of all non-parallel parking spaces. The minimum stall size for compact cars is 8 feet x 16 feet and signage and pavement markings shall be installed

identifying compact car spaces. One hundred (100) square feet of maneuvering area shall be provided for each parking space in a lot.

9.5.2.7. Handicapped parking spaces shall be provided in compliance with all applicable regulations.



Parking is internal to a block.



Screening of surface parking lots.

9.6 Landscaping

Street Trees

The planting of deciduous street trees in sidewalks at a maximum spacing of forty (40) linear feet shall be required for residential projects which abut streets that do not have street trees.

All plantings shall be native species. Invasive plant species are prohibited. Plants located near streets, driveways or parking lots must be salt-tolerant.

Planting selections shall vary from block to block to increase overall resistance to disease and infestation.

Street trees shall be installed in metal grates at least 16 square feet in area to allow for infiltration of rain water.

Street trees shall be a minimum of 3" caliper measured at breast level.

Min. depth of plantings(?)

Where feasible, the practice of continuous trench planting should be incorporated.



Natural Site Features

In establishing the development capability of the site, the following shall be taken into account:

Erosion prevention and control, including but not limited to compliance with an approved stormwater drainage management plan.

Preservation of existing trees on a site proposed for development, as well as other native site vegetation, including protection of natural area buffer zones.

Conservation of water, including but not limited to preservation of existing native vegetation, reduction in amounts of irrigated areas, and similar considerations.

Stream corridor and wetland protection and buffering, particularly in proximity to the Salisbury River.

The practical needs of approved construction activity in terms of ingress and egress to the developed project and necessary staging and operational areas.



9.6 Landscaping

On-Site Open Space

Open space must be designed to be accessible and visible from the building.

Development Projects on sites that abut the Salisbury River shall provide public pedestrian access, and should be carefully planned to enhance the visual features of this waterway.

To minimize water consumption, the use of low water vegetative ground cover other than turf, such as _____, is encouraged.



Street-Furniture

Landscaping improvements may include amenities such as street furniture, artwork, fences, stone walls, fountains, and courtyards.

Development Projects proposed on lots with frontage on lots with frontage on the Salisbury River should provide public amenities, such as benches and walkways, near the water body.